



CESSNA 195 ARF 90" WINGSPAN 35-50cc

Code : SEA409

ASSEMBLY MANUAL

"Graphics and specifications may change without notice".



Specifications:

Wingspan-----	228.8 cm-----	90 inches.
Length-----	183.1 cm-----	72 inches.
Wing area-----	89.16 sq.dm-----	1382 sq.in.
Weight-----	8.5 - 9 kg-----	18.7 - 19.8 lbs.
Engine-----	35cc - 50cc.	
Radio-----	8 channels 8 servos.	
Motor: Recommend :	60XX motor size or more.	
Propellers-----	18x12 or 19x10.	



INTRODUCTION

Thank you for choosing the **Cessna 195 ARF 90" wingspan 35-50cc**ARTF by **SG MODELS** . The **Cessna 195 ARF 90" wingspan 35-50cc** was designed with the intermediate/advanced sport flyer in mind. It is a semi scale airplane which is easy to fly and quick to assemble. The airframe is conventionally built using balsa, plywood to make it stronger than the average ARTF, yet the design allows the aeroplane to be kept light. You will find that most of the work has been done for you already. The motor mount has been fitted and the hinges are pre-installed. Flying the **Cessna 195 ARF 90" wingspan 35-50cc** is simply a joy.

This instruction manual is designed to help you build a great flying aeroplane. Please read this manual throughly before starting assembly of your **Cessna 195 ARF 90" wingspan 35-50cc** Use the parts listing below to indentify all parts.

WARNING

Please be aware that this aeroplane is not a toy and if assembled or used incorrectly it is capable of causing injury to people or property. WHEN YOU FLY THIS AEROPLANE YOU ASSUME ALL RISK & REponsibility.

If you are inexperienced with basic R/C flight we strongly recommend you contact your R/C supplier and join your local R/C model Flying Club. R/C Model Flying Clubs offer a variety of training proceduredesigned to help the new pilot on his way to successful R/C flight. They will also be able to advise on any insurance and safety regulations that may apply.

KIT CONTENTS

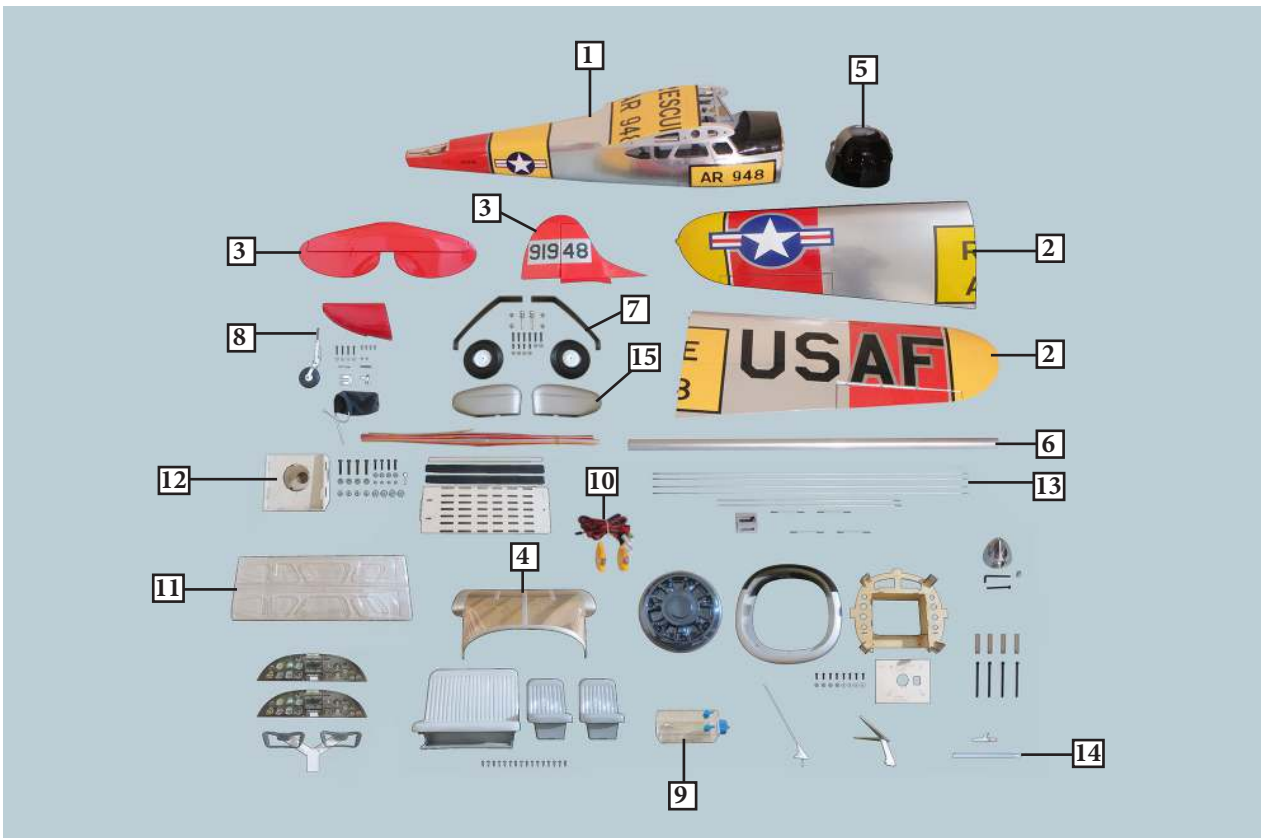

KIT CONTENTS

SEA409: Cessna 195 ARF 90" wingspan 35-50cc

1. Fuselage
2. Wing set (2)
3. Tail set (3)
4. Canopy
5. Cowling
6. Wing tube
7. Landing gear
8. Tail wheel
9. Fuel tank
10. Led light set
11. Windows
12. Ep Motor box
13. Pushrod
14. Pitot Tube (Prot Wing)
15. Wheel cover

ADDITIONAL ITEMS REQUIRED

- 35-50cc gasoline engine.
- Computer radio 8 channel with 8 servos.
- Glow plug to suit engine.
- Propeller to suit engine.
- Protective foam rubber for radio system.

TOOLS & SUPPLIES NEEDED

- Thin cyanoacrylate glue.
- Medium cyanoacrylate glue.
- 30 minute epoxy.
- 5 minute epoxy.
- Hand or electric drill.
- Assorted drill bits.
- Modelling knife.
- Straight edge ruler.
- 2mm ball driver.
- Phillips head screwdriver.
- 220 grit sandpaper.
- 90° square or builder's triangle.
- Wire cutters.
- Masking tape & T-pins.
- Thread-lock.
- Paper towels.

LED LIGHT SET

Please see pictures below.

1.

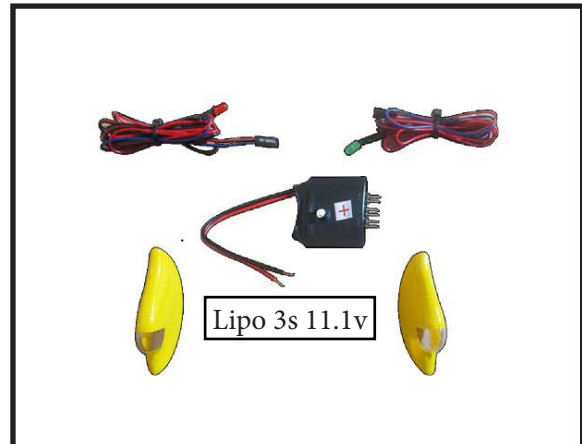

One the green light for right wing tip, two white light and the red light for left wing tip. They are designed to operate on voltages 12 volts. Connect four lights into switch circuit so that optional the different flashes mode.

2.

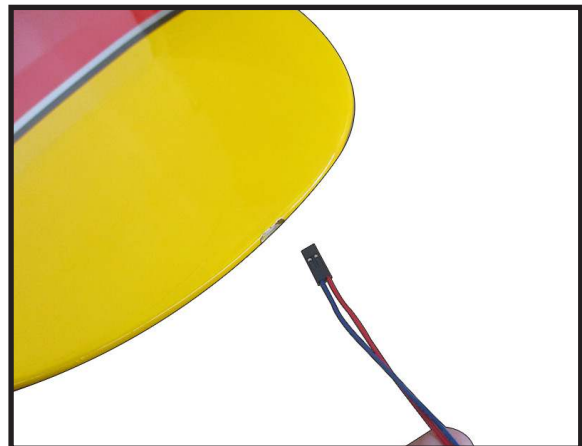

3.

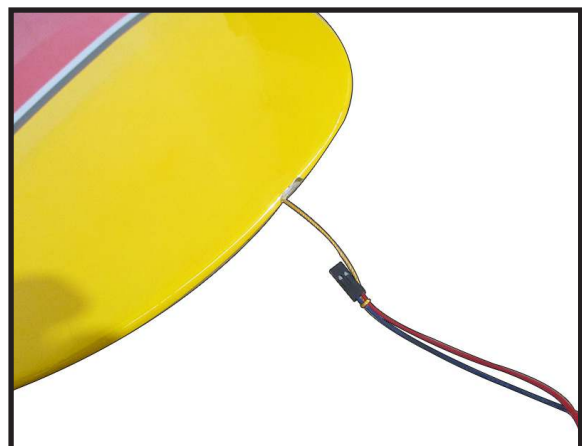

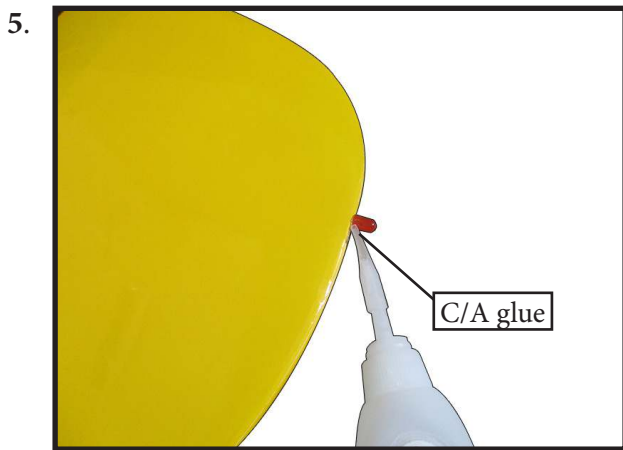
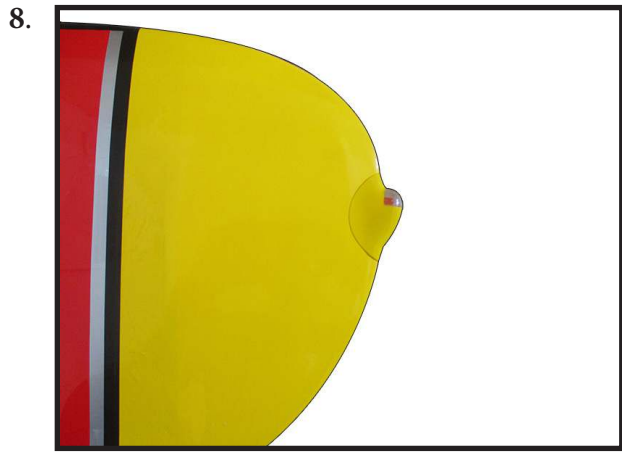

HINGING THE FLAP

Please see pictures below.

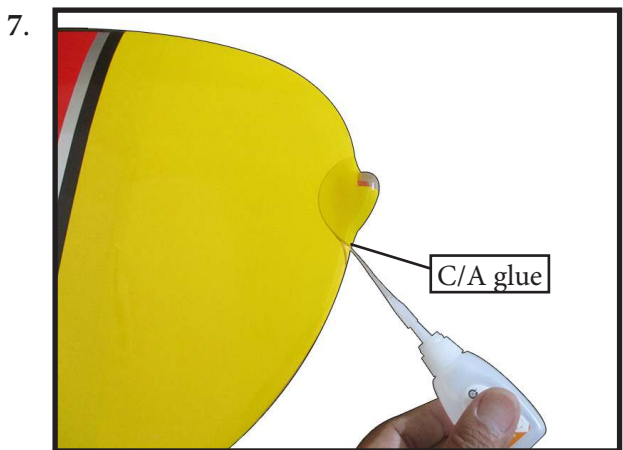
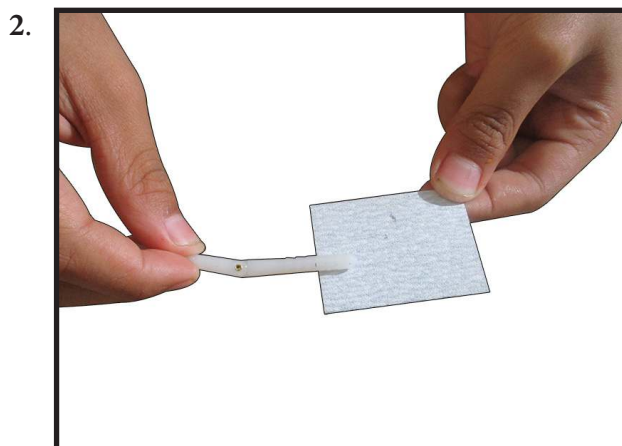
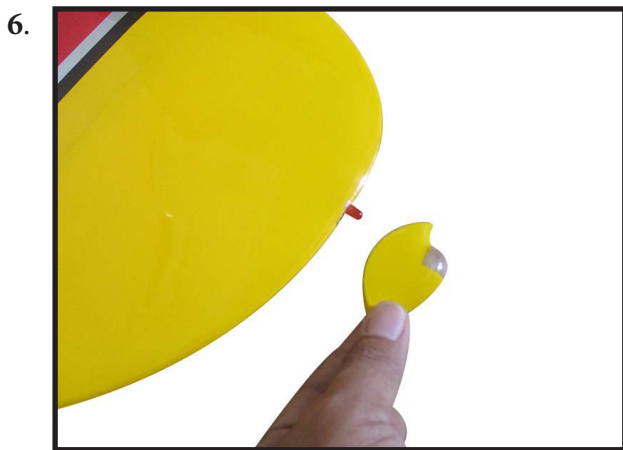
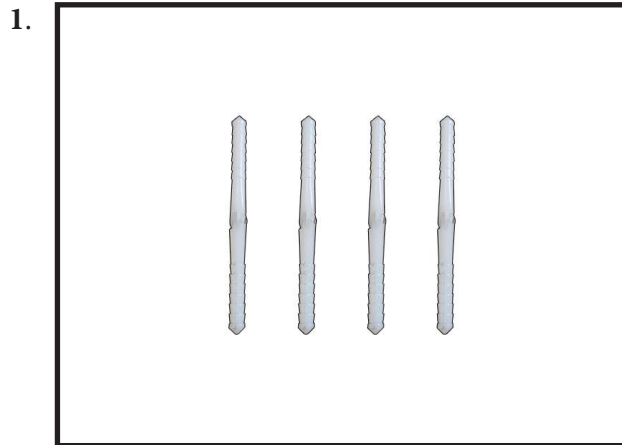

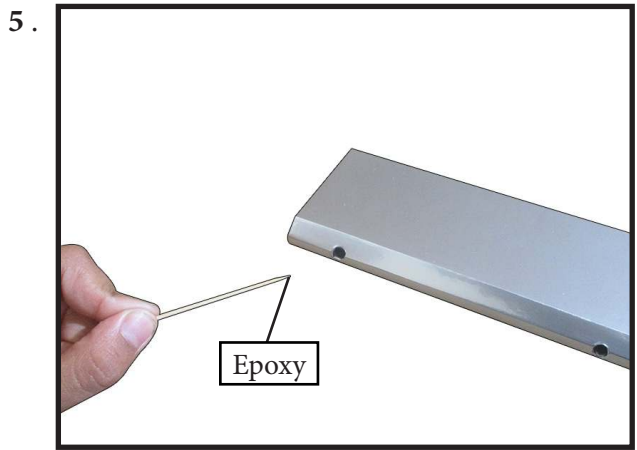
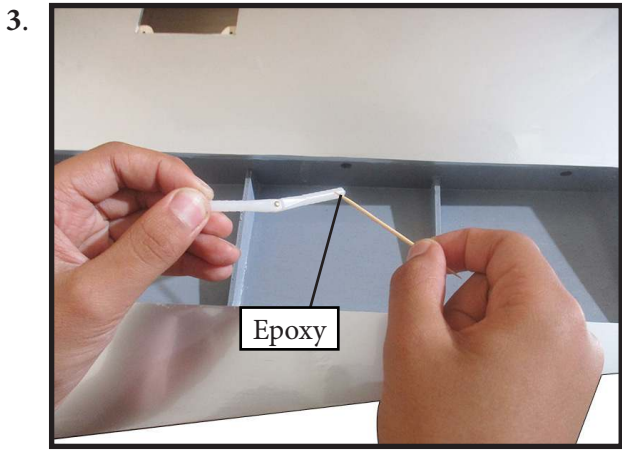

INSTALL THE AILERONS

Please see pictures below.

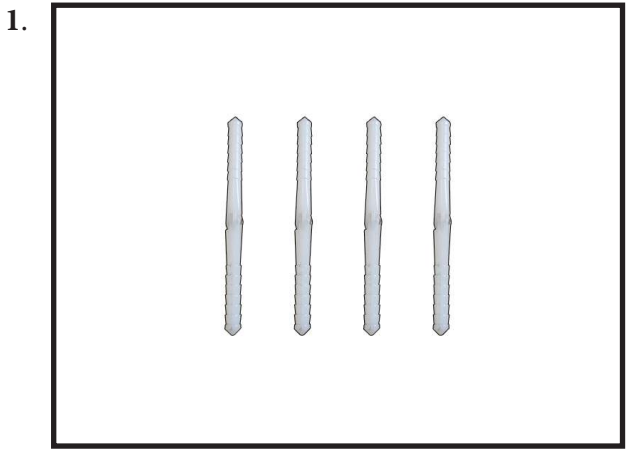

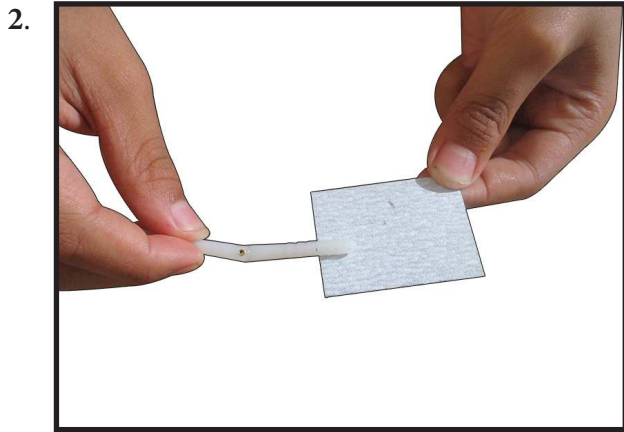

Remove the ailerons from the wing and remove the hinges.

Use a small piece of rough sandpaper to scuff the hinges for better epoxy adhesion. Do this to all aileron hinges.

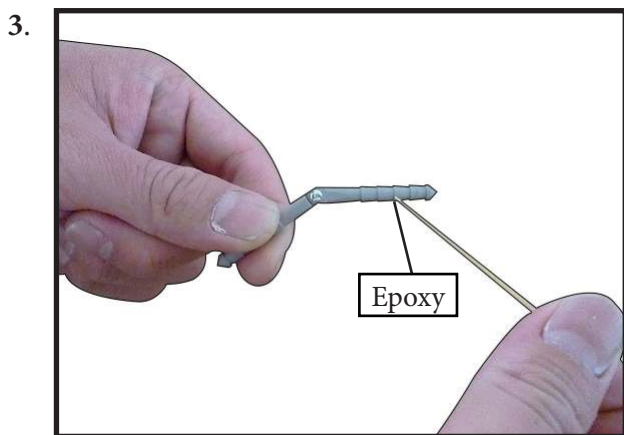

Apply epoxy to each hinge where it will be inserted into the ailerons. Tip: Apply some petroleum jelly to the metal pin hinge area to keep epoxy from interfering with smooth operation of hinge.

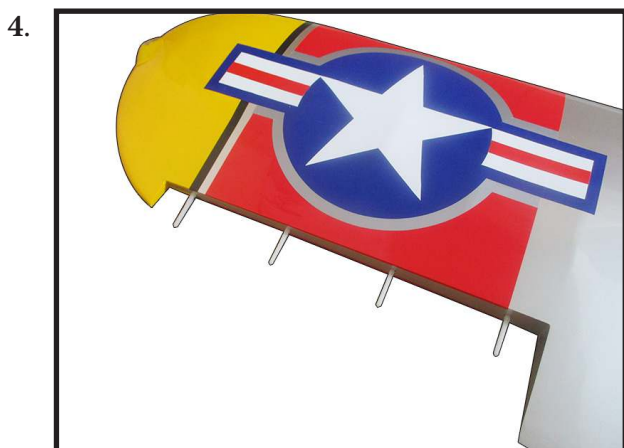

Insert all four hinges in the ailerons at this time. Make sure hinges move up and down in right direction and not side to side !

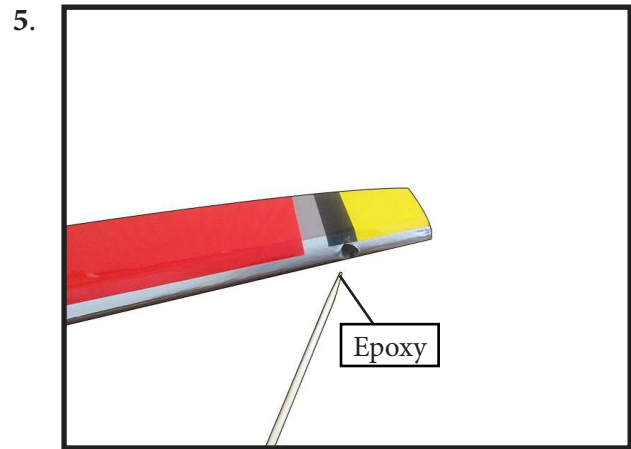

Apply epoxy into each of the holes in the ailerons using a spare piece of pushrod wire or toothpick.

Make sure to use enough epoxy so it securely adheres the hinge to the surfaces.

Do not use an excessive amount of epoxy when gluing the hinges so that it expels from the hinge area.

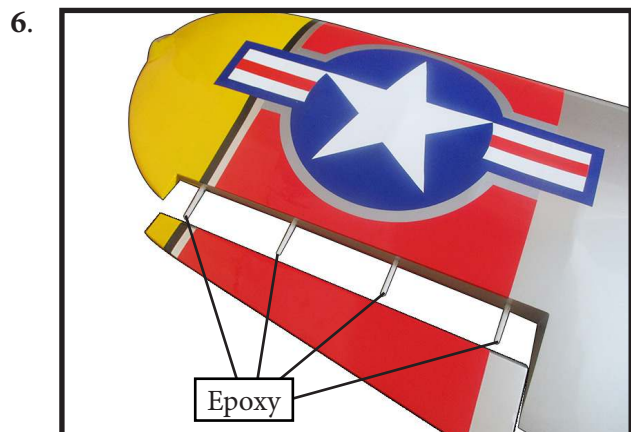

Be sure to test the aileron hinges once you insert them. Ensure that the hinge pockets line up, and that the hinges move freely before the epoxy dries.

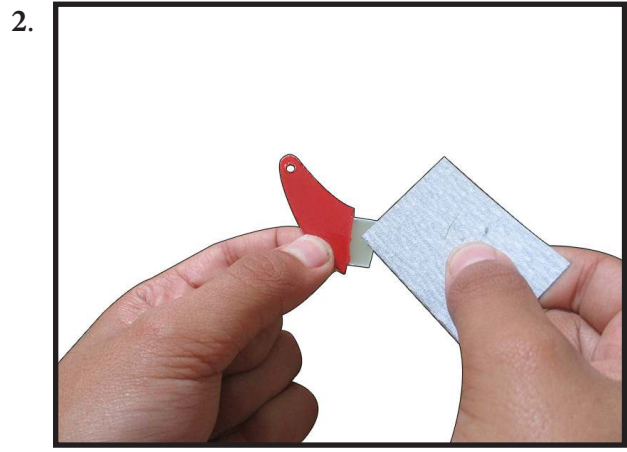
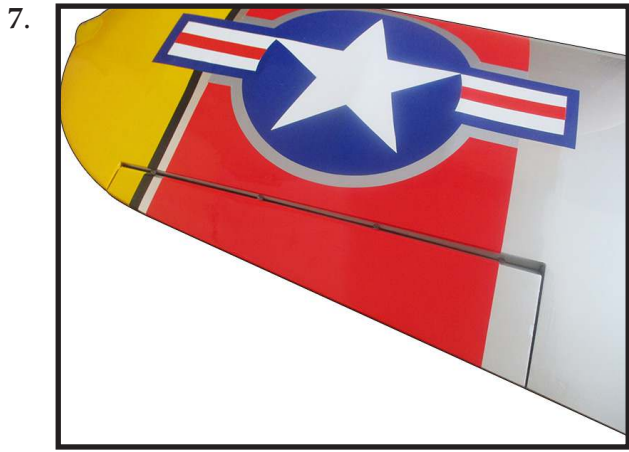

Check the fit of the aileron to the wing. The top of the ailerons will align to the top of the wing. Make sure movement is smooth and bind free.

We prefer 30-minute epoxy to allow enough working time during the hinge installation.

INSTALL THE AILERONS CONTROL HORN

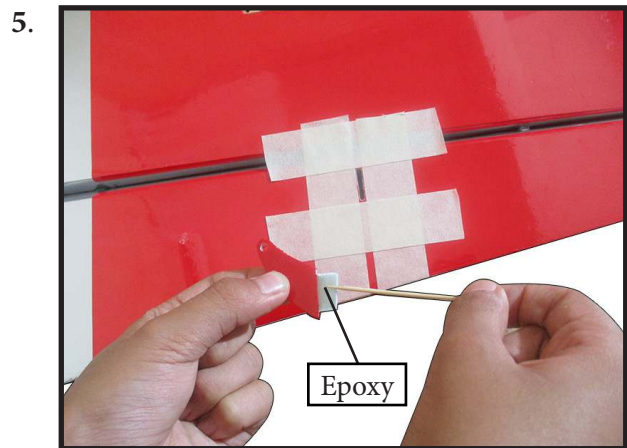
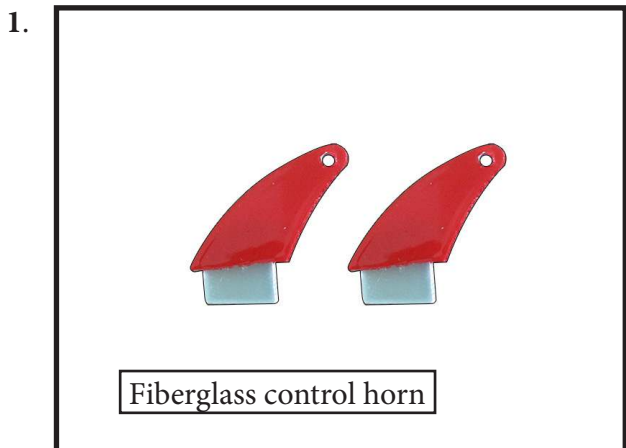
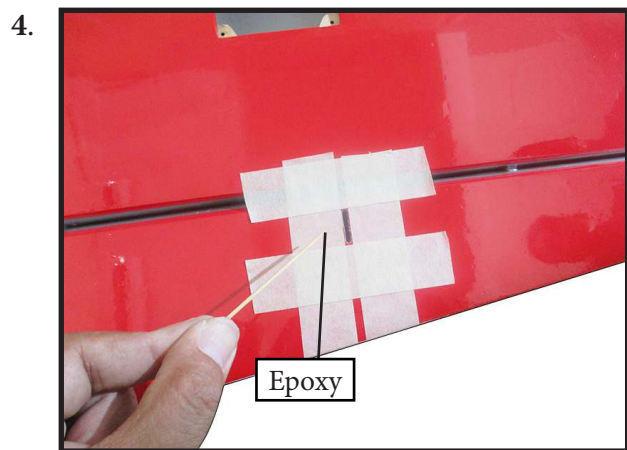

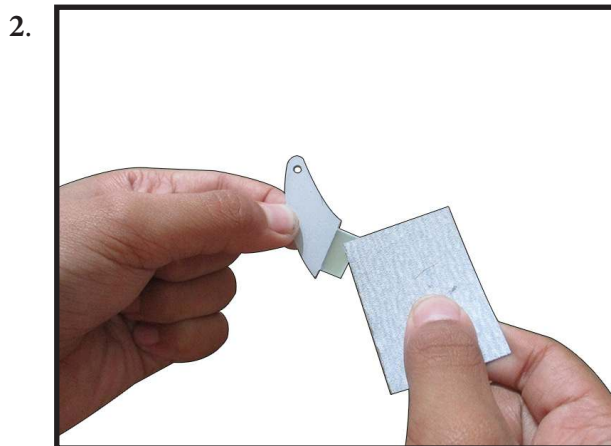
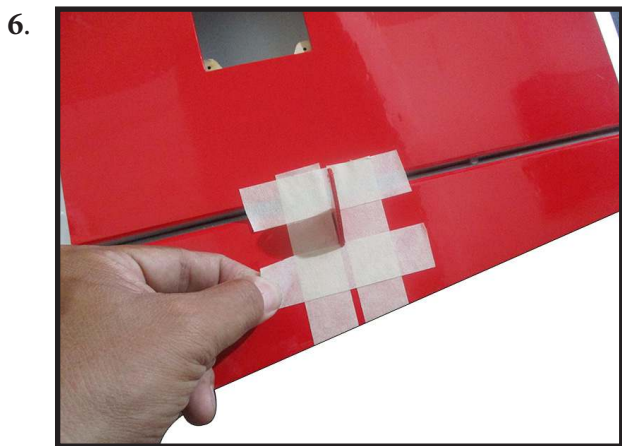

INSTALL FLAP CONTROL HORN

Install the flap control horn using the same method as same as the aileron control horns.

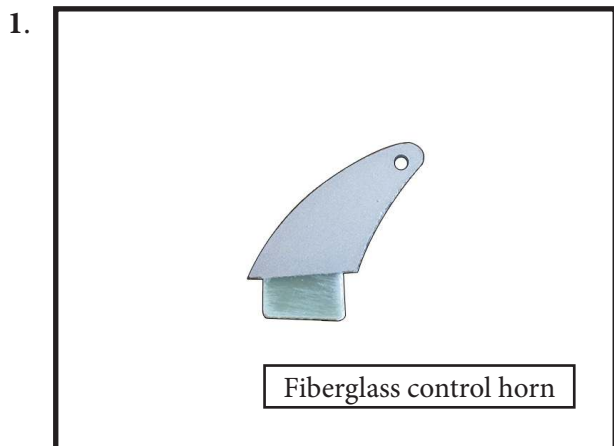

INSTALLING THE AILERON SERVOS

1.

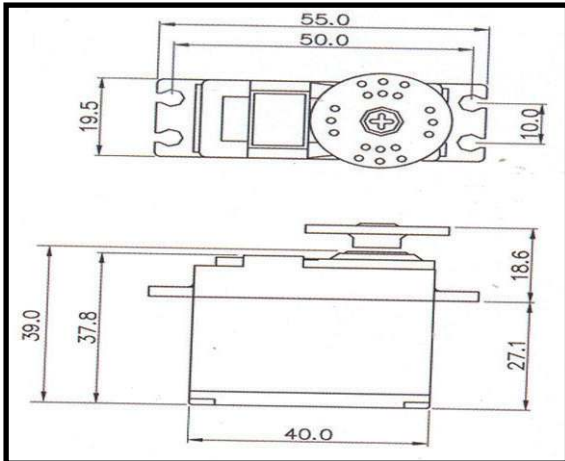

2.

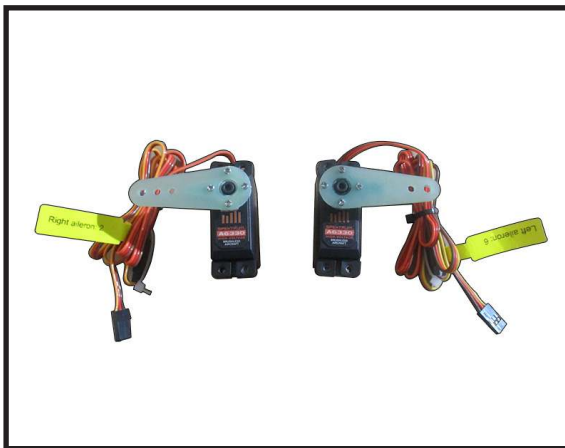

Maximum Servo spec.
Torque : 126.6 oz-in (9.11 kg-cm) @ 6.0V;
178 oz-in (12.82 kg-cm) @ 7.4V; 248 oz-in (17.86 kg-cm) @ 8.4V

 Because the size of servos differ, you may need to adjust the size of the precut opening in the mount. The notch in the sides of the mount allow the servo lead to pass through.

Apply 2-3 drops of thin C/A to each of the mounting holes. Allow the C/A to cure without using accelerator.

3.

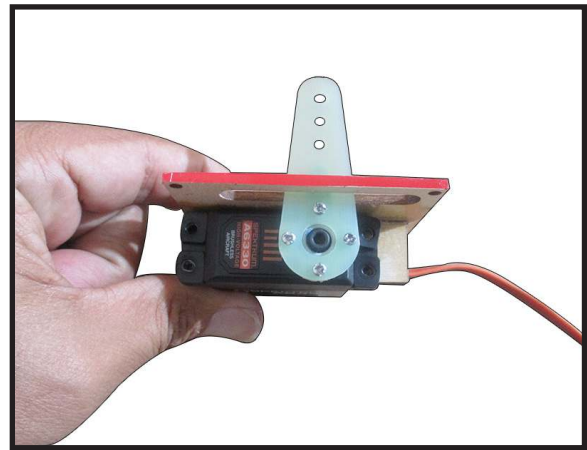

Use drill bit in a pin vise to drill the mounting holes in the blocks.

4.

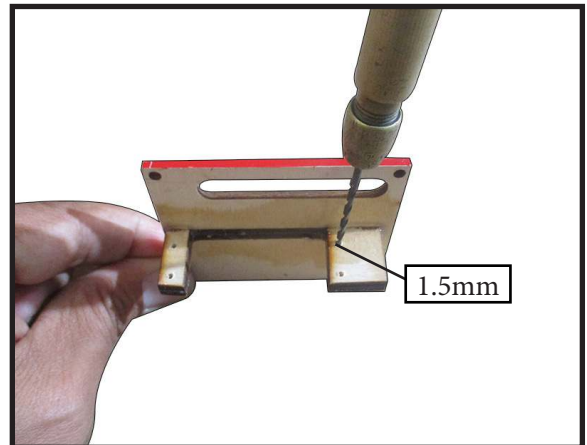

Apply 2-3 drops of thin C/A to each of the mounting holes. Allow the C/A to cure without using accelerator.

5.

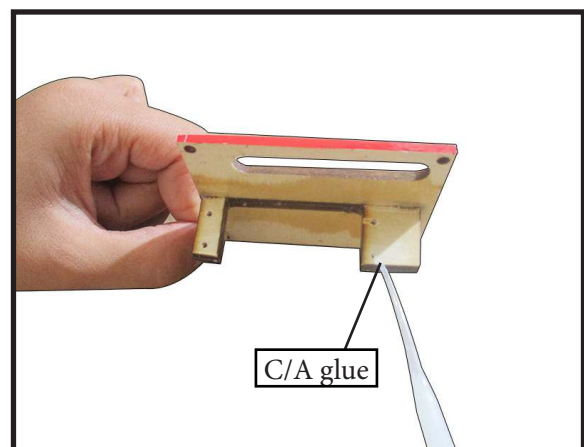

Use dental floss or heat shrink tubing to secure the connection between the servo and extension wire so they cannot become unplugged accidentally.

Use dental floss or heatshrunk tube to secure the connection so they cannot become unplugged.

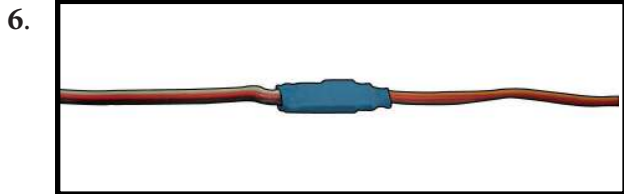

Secure the servo to the aileron hatch using Phillips screwdriver and the screws provided with the servo.

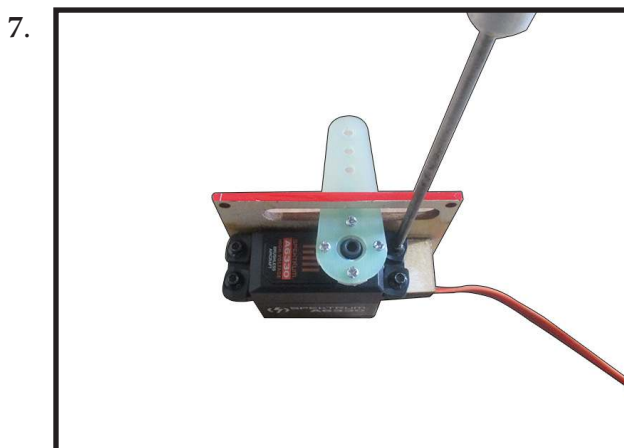

Apply 1-2 drops of thin C/A to each of the mounting tabs. Allow the C/A to cure without using accelerator.

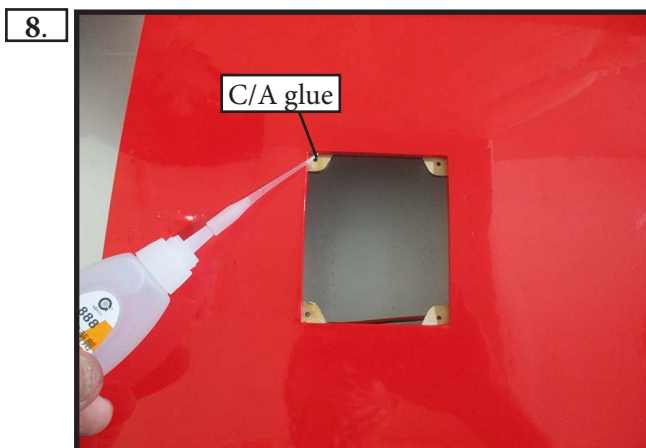

Remove the string from the wing at the servo location and use the tape to attach it to the servo extension lead. Pull the lead through the wing and remove the string.

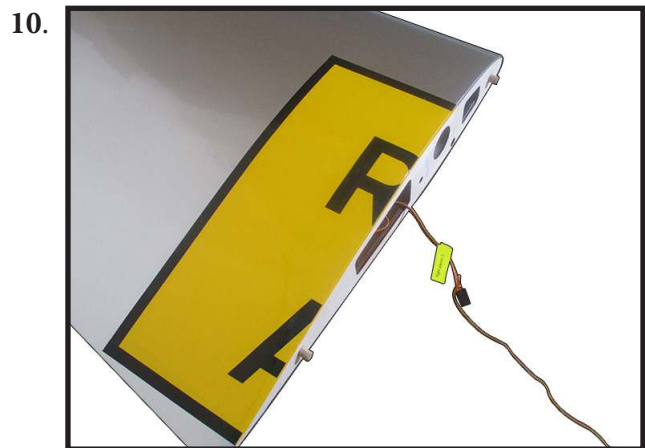
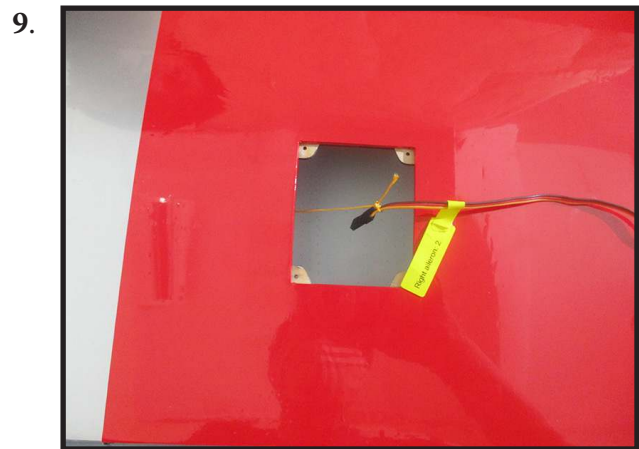

12.



Set the aileron hatch in place and use a Phillips screw driver to install it with four wood screws.

13.

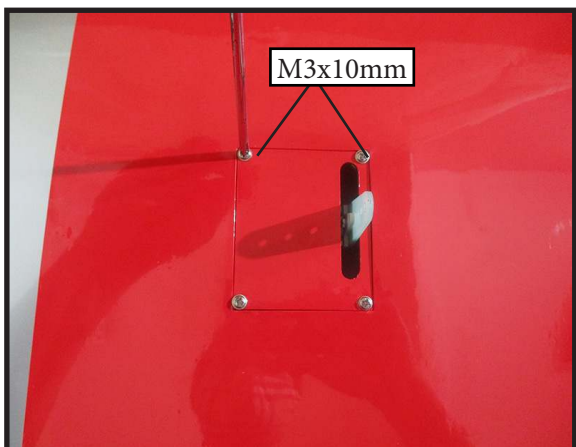

14.



AILERON PUSHROD INSTALLATION

Please see below pictures.

1.

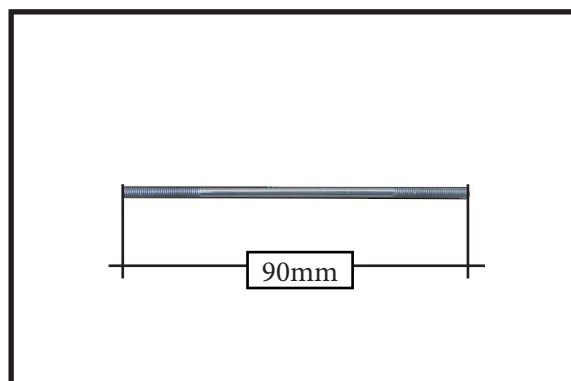

2.



3.

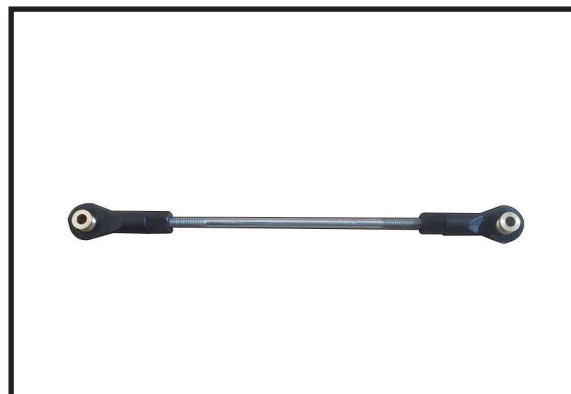

4.

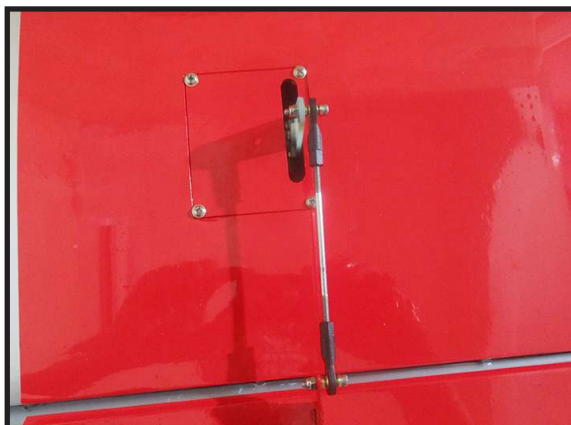

INSTALLING THE FLAP PUSHROD

Please see below pictures.

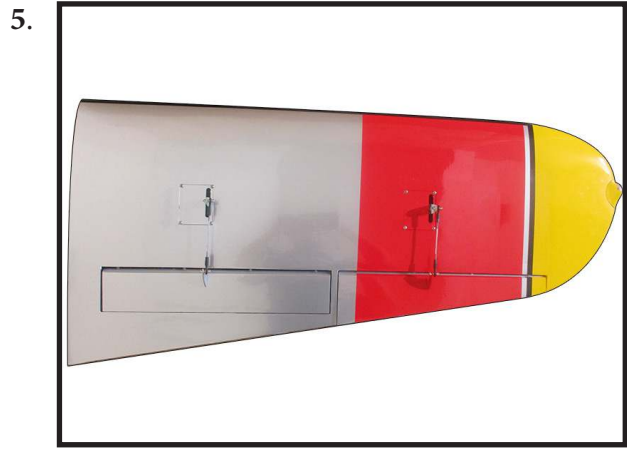
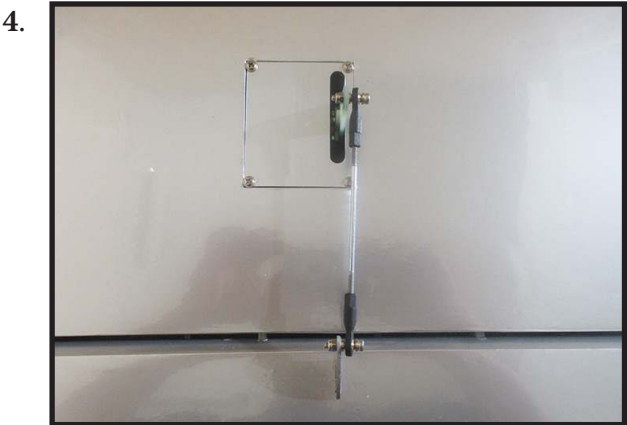
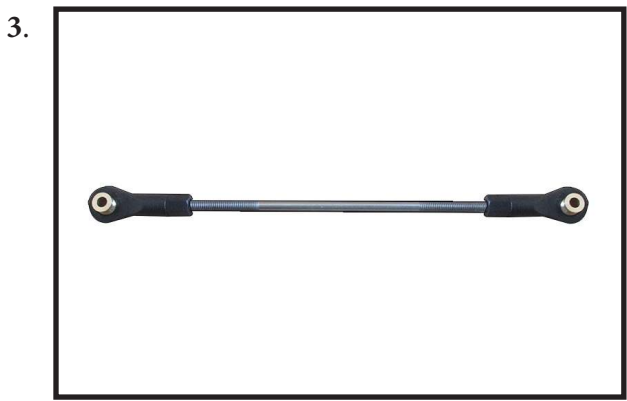
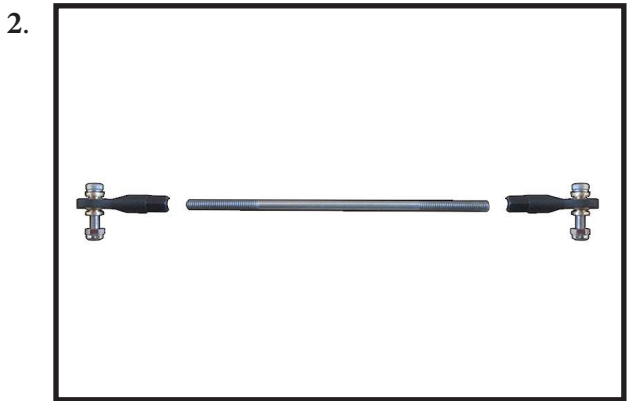
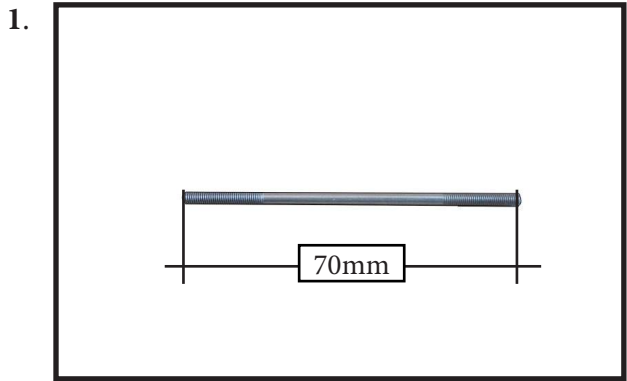

Install plastic ribs.

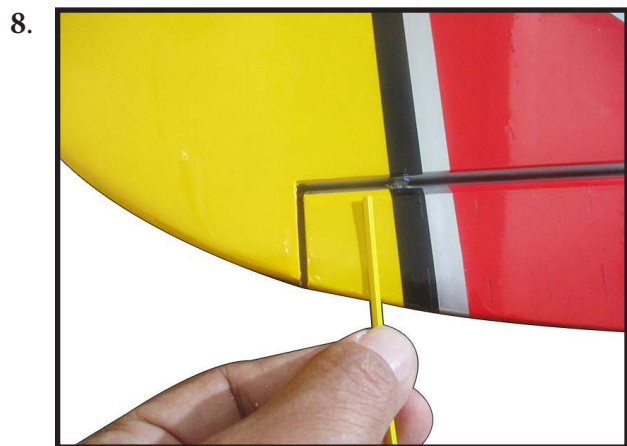
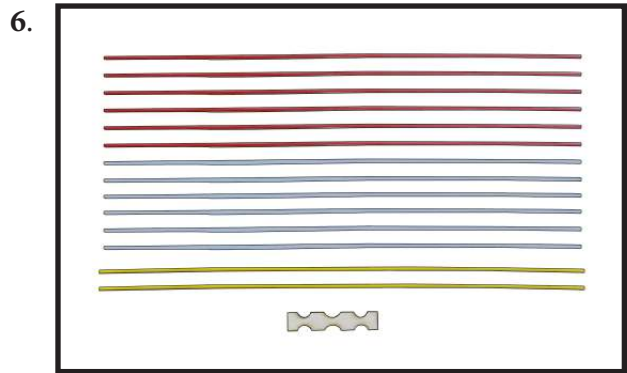

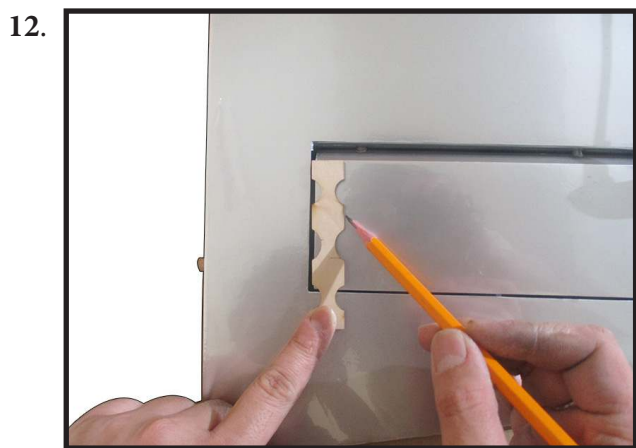
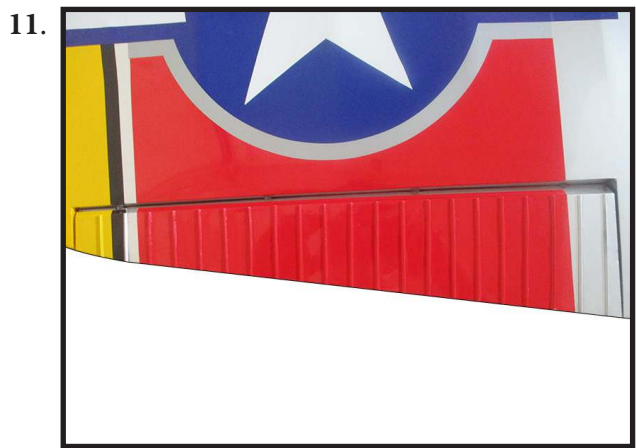
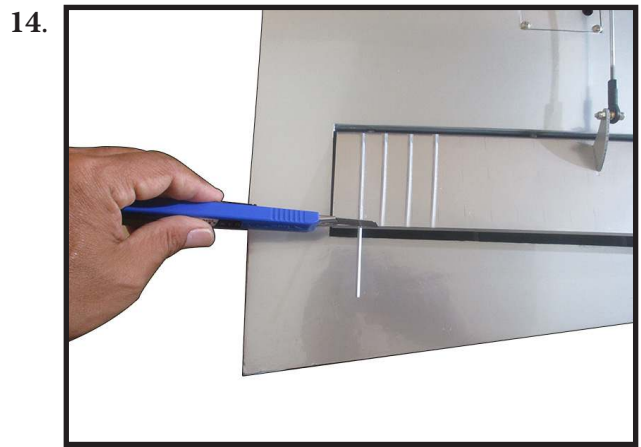
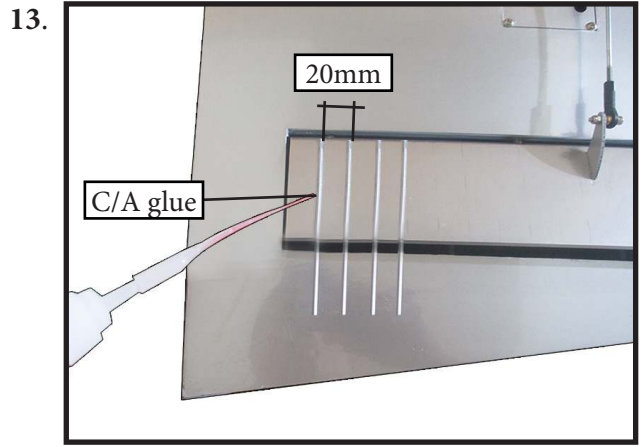
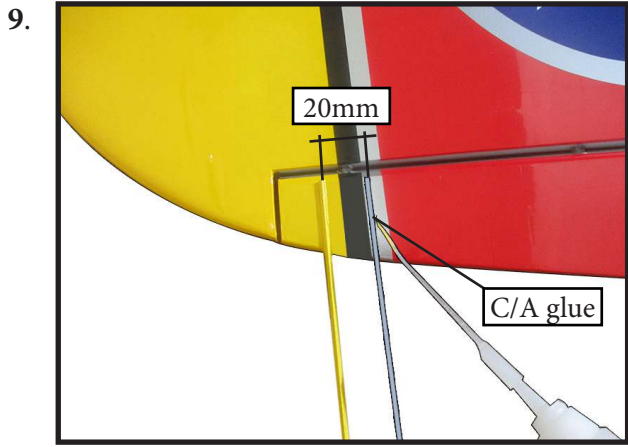

INSTALL ELEVATOR HINGES

Test fit the hinges into the elevator, and then the hinges into the horizontal stabilizer. Ensure that the hinge pockets line up, and that the hinges move freely. Epoxy hinge the same way you did the aileron hinges.

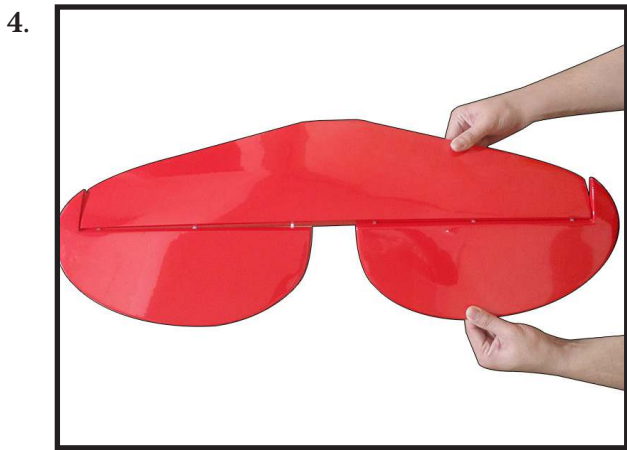
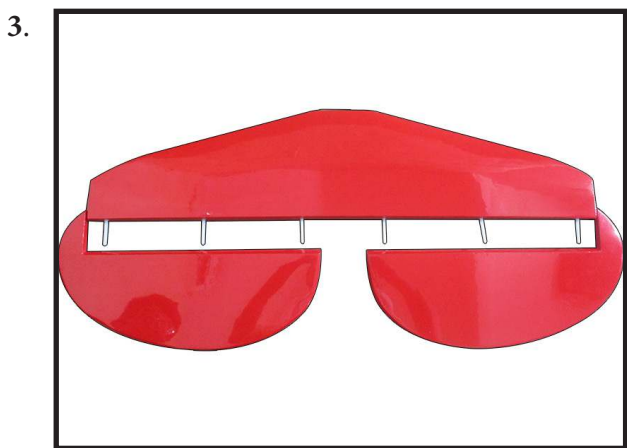
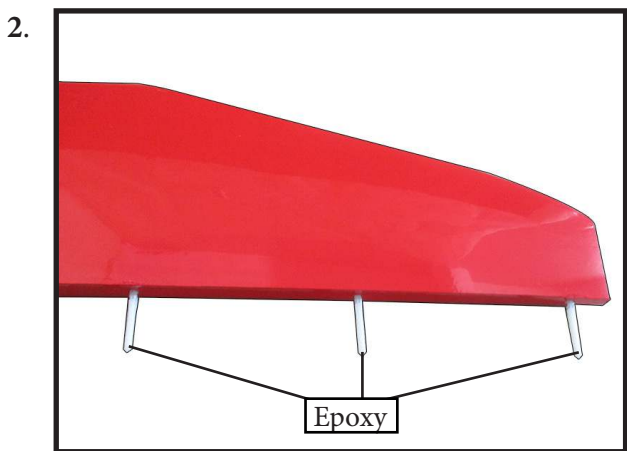
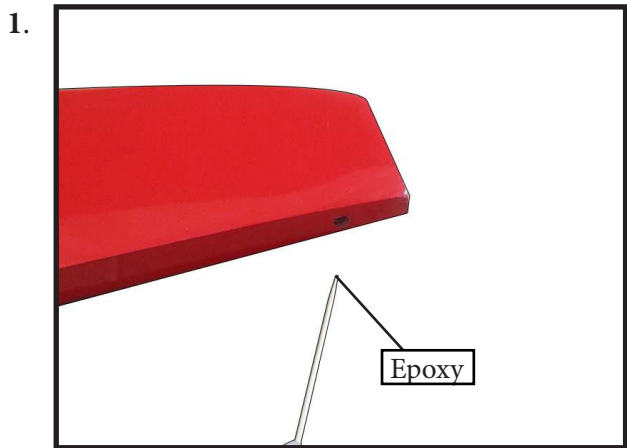

INSTALL ELEVATOR CONTROL HORN

Install the elevator control horn using the same method as same as the elevator control horns.

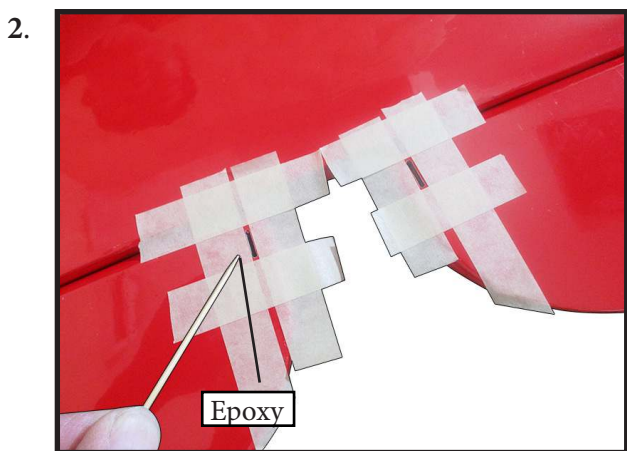

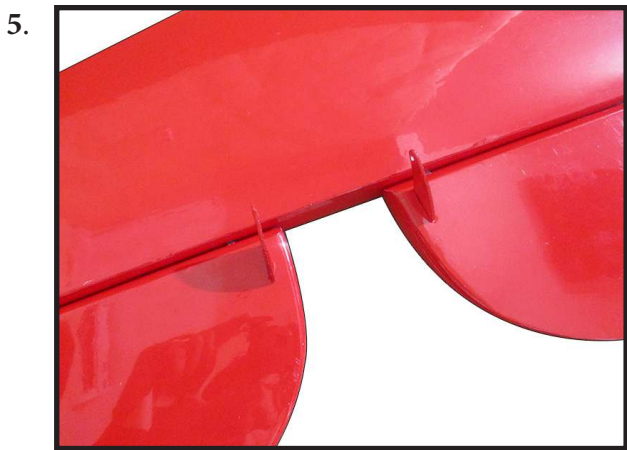
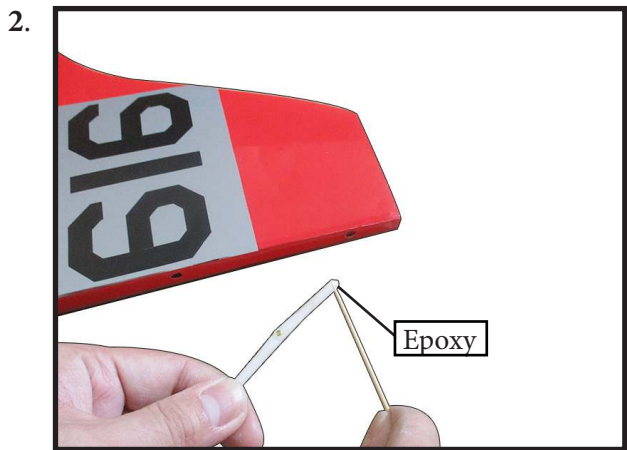
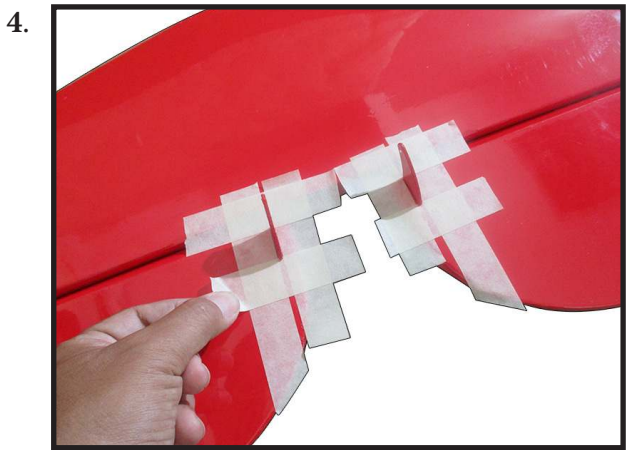
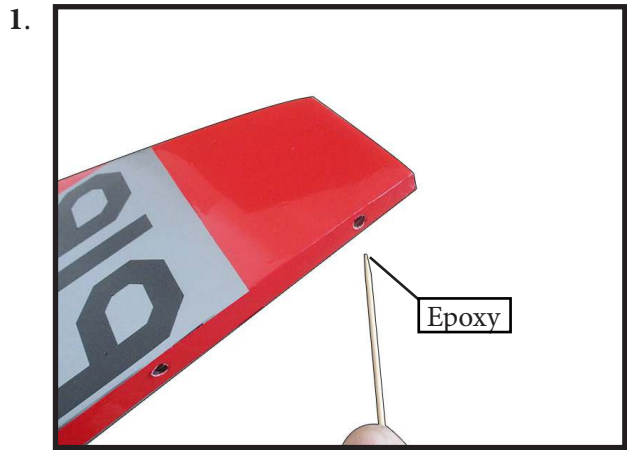
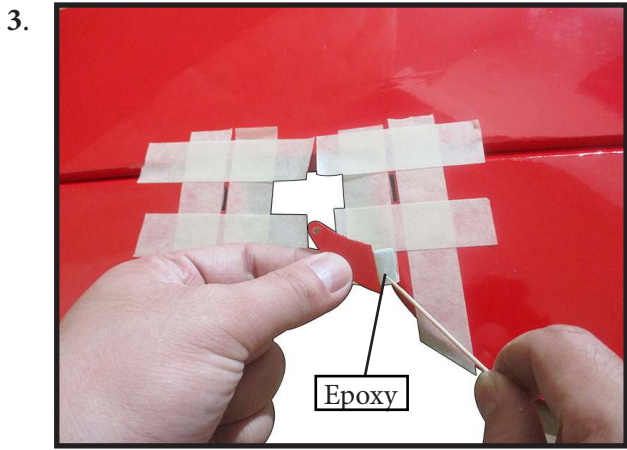

INSTALL NAIL HINGE RUDDER

Test fit the hinges into the rudder, and then the hinges into the tail. Ensure that the hinge pockets line up, and that the hinges move freely.



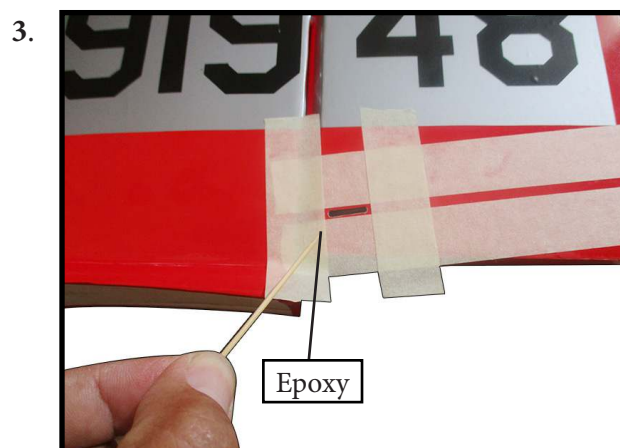
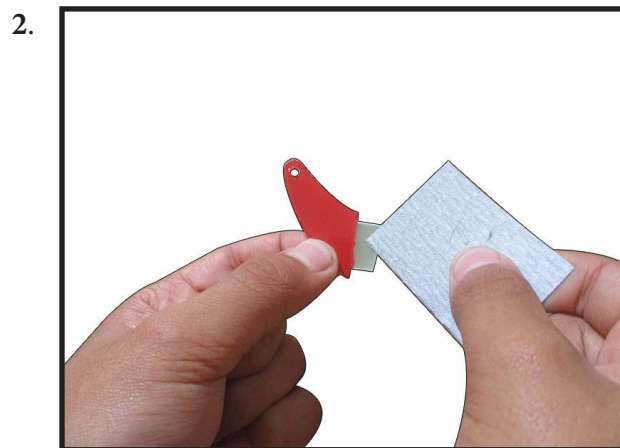

INSTALL RUDDER CONTROL HORN

Repeat steps to install the rudder control horn as same as steps done for elevator.

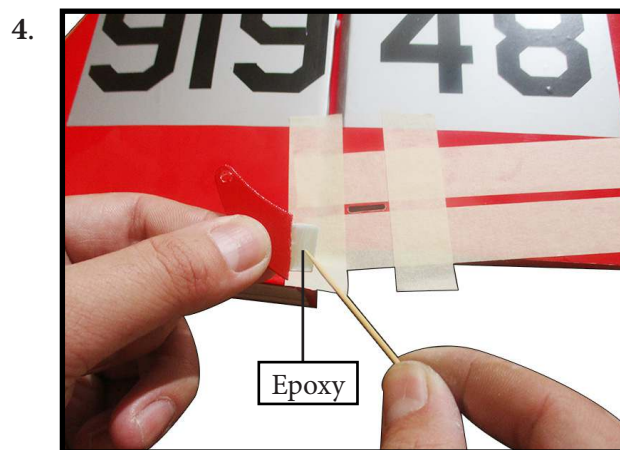
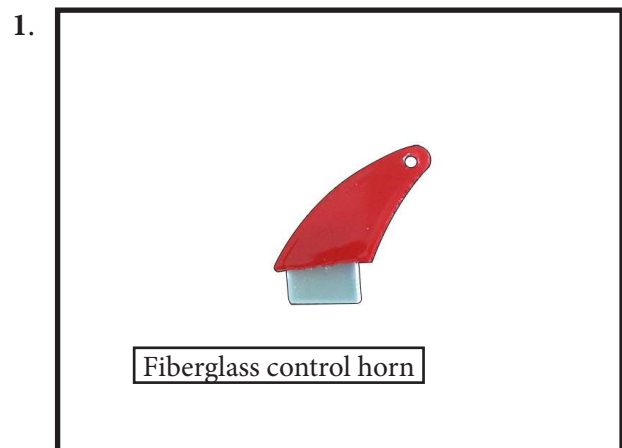

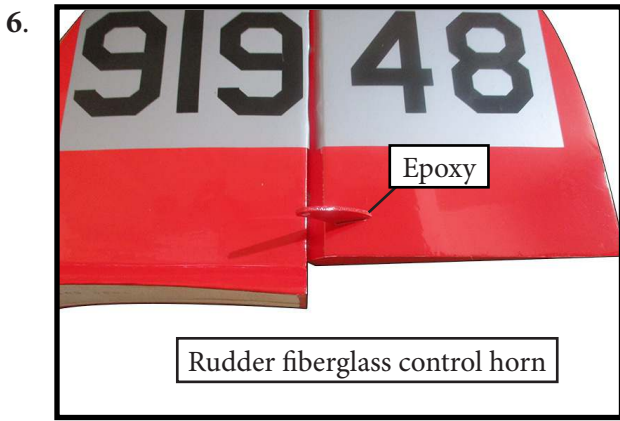

INSTALLING THE HORIZONTAL STABILIZER

Using a ruler and a pen, locate the centerline of the horizontal stabilizer, at the trailing edge, and place a mark. Use a triangle and extend this mark, from back to front, across the top of the stabilizer. Also extend this mark down the back of the trailing edge of the stabilizer.

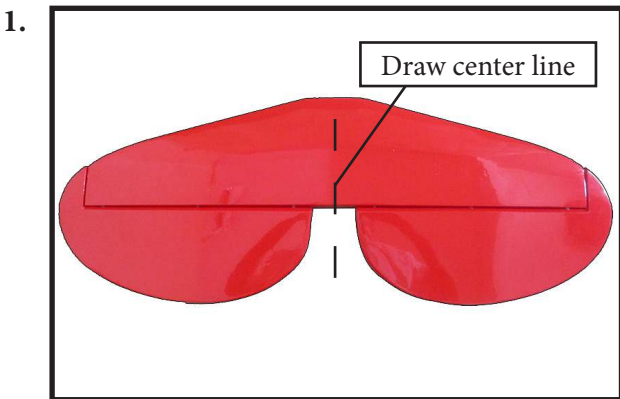

Using a modeling knife, carefully remove the covering at mounting slot of horizontal stabilizer (both side of fuselage).

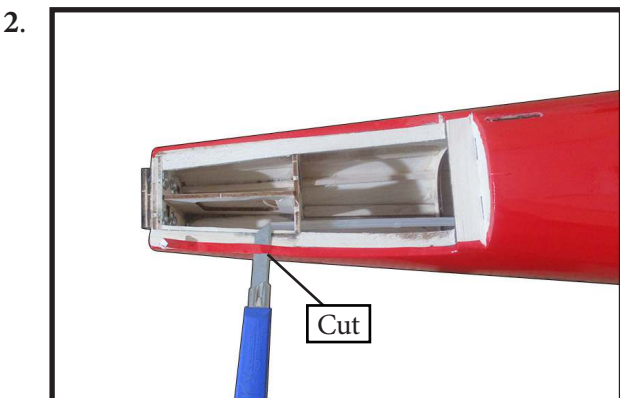

Slide the stabilizer into place in the precut slot in the rear of the fuselage. The stabilizer should be pushed firmly against the front of the slot.

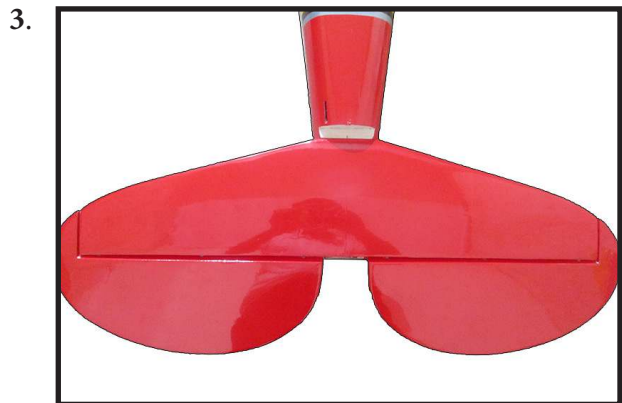

With the stabilizer held firmly in place, use a pen and draw lines onto the stabilizer where it and the fuselage sides meet. Do this on both the right and left sides and top and bottom of the stabilizer.

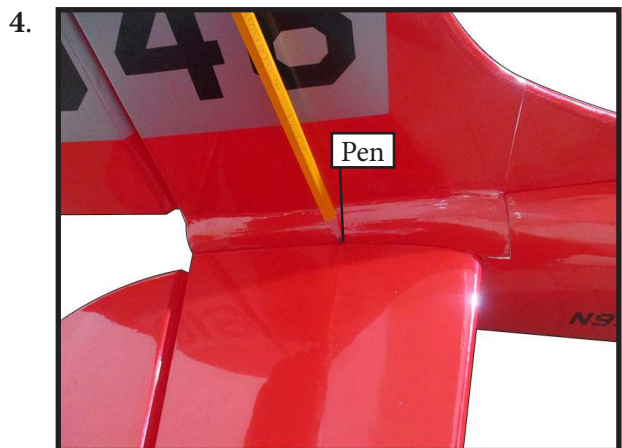

Remove the stabilizer. Using the lines you just drew as a guide, carefully remove the covering from between them using a modeling knife.

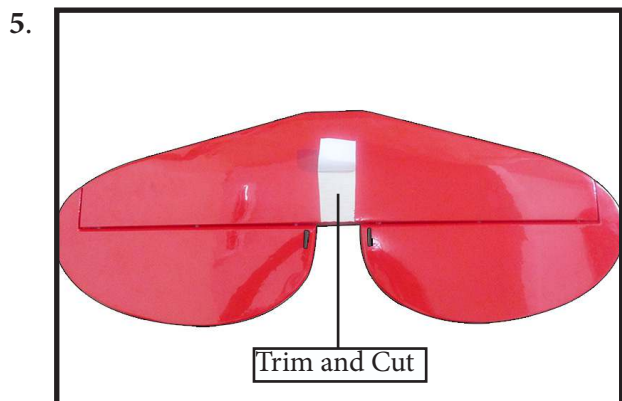

 *When cutting through the covering to remove it, cut with only enough pressure to only cut through the covering itself. Cutting into the balsa structure may weaken it.*

Using a modeling knife, carefully remove the covering that overlaps the stabilizer mounting platform sides in the fuselage. Remove the covering from both the top and the bottom of the platform sides.

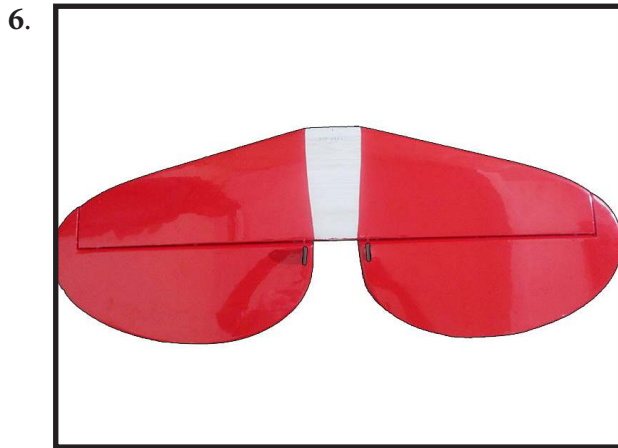

When you are sure that everything is aligned correctly, mix up a generous amount of 30 Minute Epoxy. Apply a thin layer to the top and bottom of the stabilizer mounting area and to the stabilizer mounting platform sides in the fuselage. Slide the stabilizer in place and realign. Double check all of your measurements once more before the epoxy cures. Hold the stabilizer in place with T-pins or masking tape and remove any excess epoxy using a paper towel and rubbing alcohol.

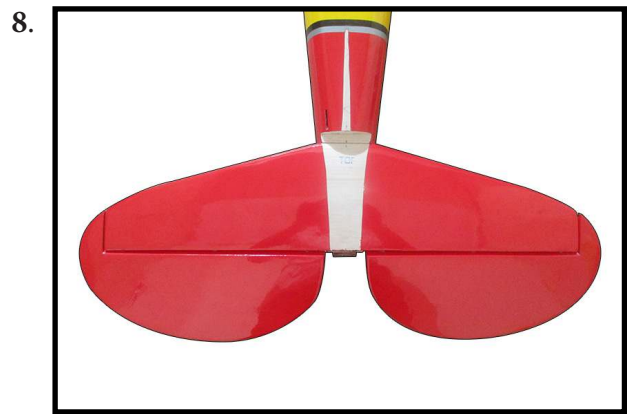
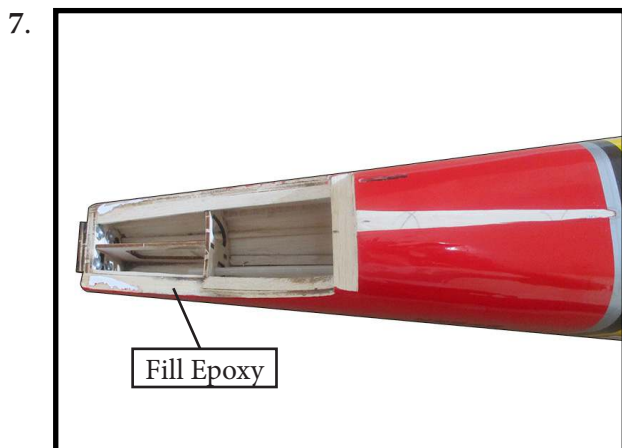

INSTALLING VERITICAL FIN

Required Parts

- Fuselage assembly
- Tail Set(Rudder and Elevator)

Required Tools and Adhesives

- Ruler, Pen, Knife
- 30-mminute epoxy



Using a modeling knife, remove the covering from over the precut hinge slot cut into the lower rear portion of the fuselage.

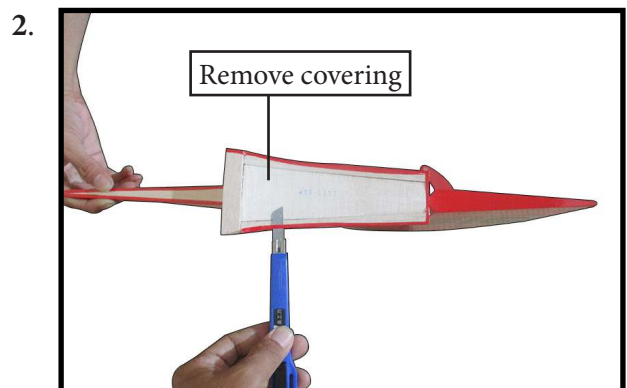

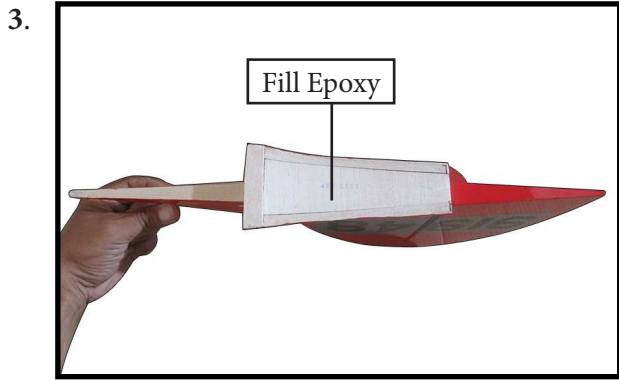

While holding the vertical stabilizer firmly in place, use a pen and draw a line on each side of the vertical stabilizer where it meets the top of the fuselage.

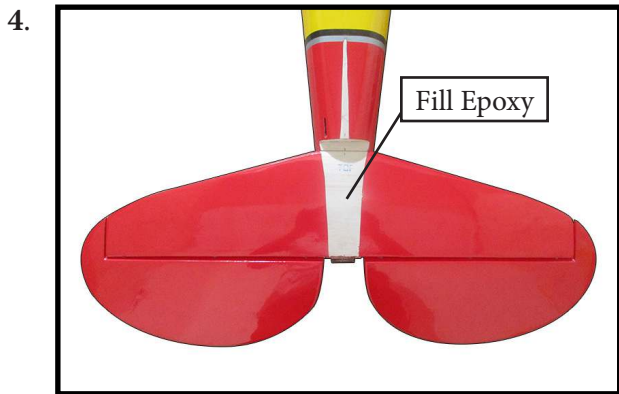

Slide the vertical stabilizer back in place. Using a triangle, check to ensure that the vertical stabilizer is aligned 90° to the horizontal stabilizer.

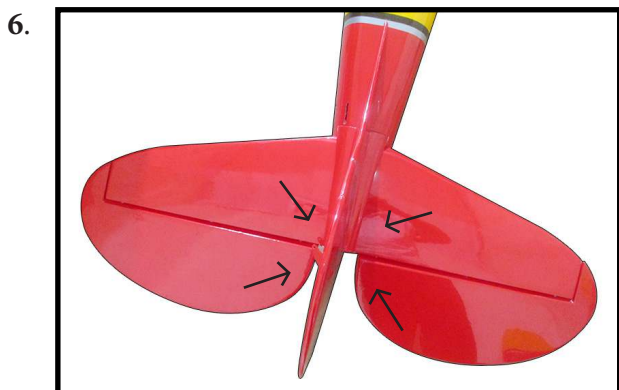
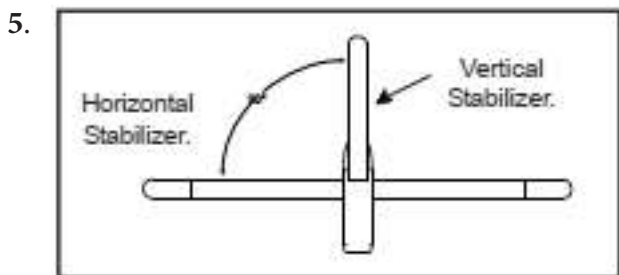

When you are sure that everything is aligned correctly, mix up a generous amount of Flash 30 Minute Epoxy. Apply a thin layer to the mounting slot and to bottom of the vertical stabilizer mounting area. Apply epoxy to the bottom and top edges of the filler block and to the lower hinge also. Set the stabilizer in place and realign. Double check all of your measurements once more before the epoxy cures. Hold the stabilizer in place with T-pins or masking tape and remove any excess epoxy using a paper towel and rubbing alcohol. Allow the epoxy to fully cure before proceeding.

ELEVATOR PUSHROD HORN INSTALLATION

Install the elevator control horn using the same method as with the aileron control horns.

Position the elevator control horns on both side of the elevator.

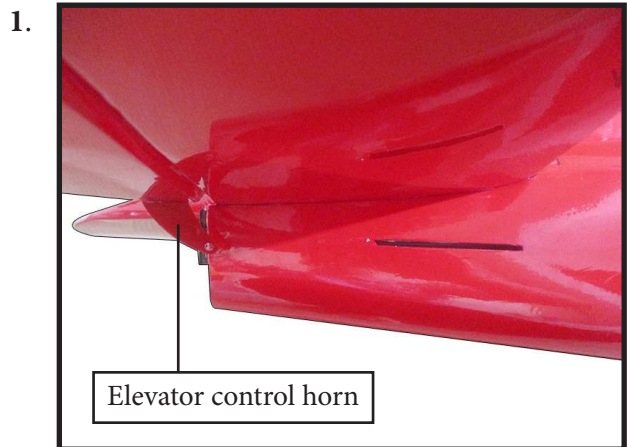

Thread one clevis and M3 lock nut on to each elevator control rod. Thread the horns on until they are flush with the ends of the control rods.

Assemble the elevator and rudder pushrods as shown in images below.

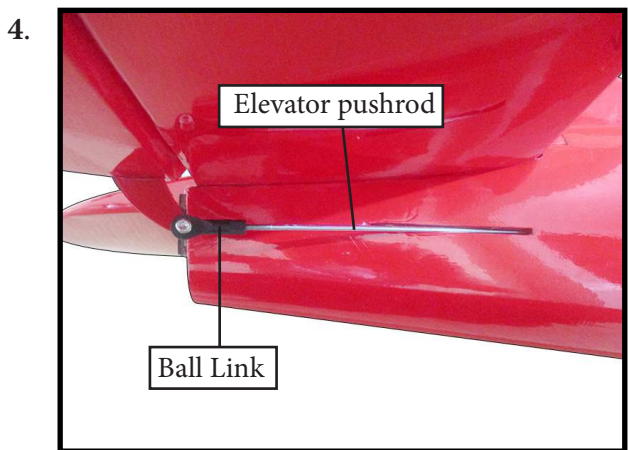
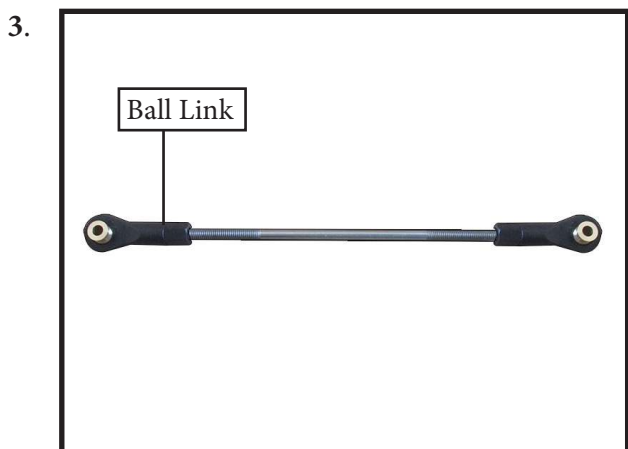
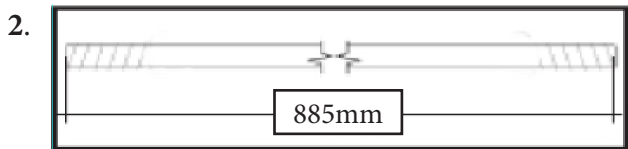

**RUDDER PUSHROD
INSTALLATION**

Locate items necessary to install rudder pushrod.



Rudder pushrods assembly as pictures below.

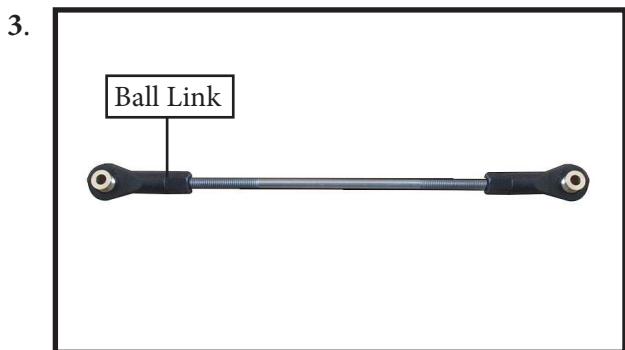
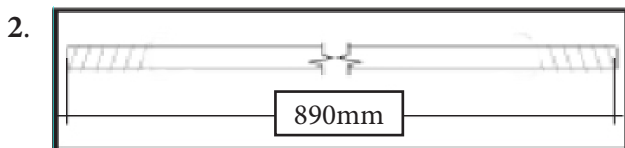

5.



MOUNTING THE TAIL WHEEL

Locate items necessary to install tail gear.

1.



2.



3.

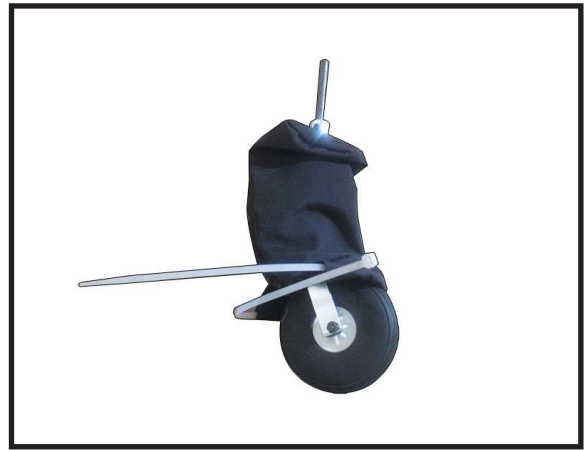

4.



5.

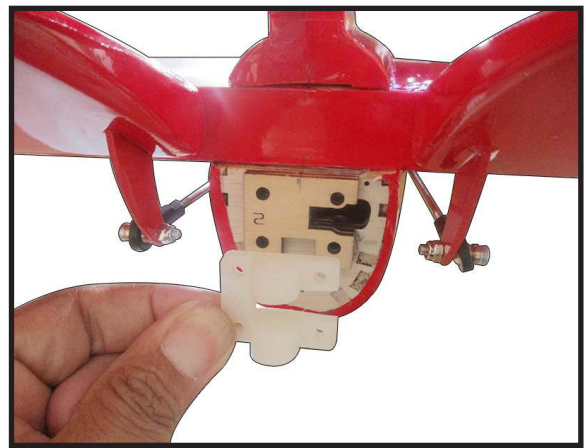

6.

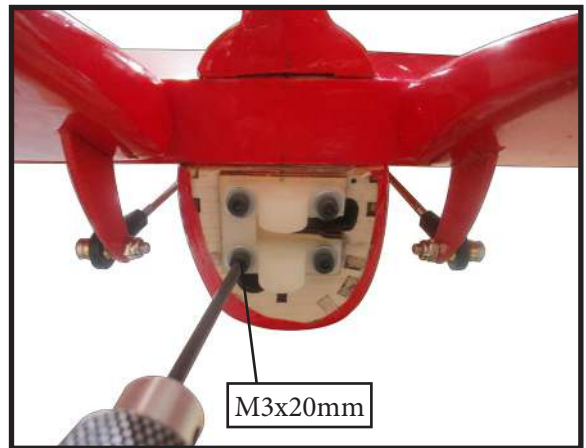

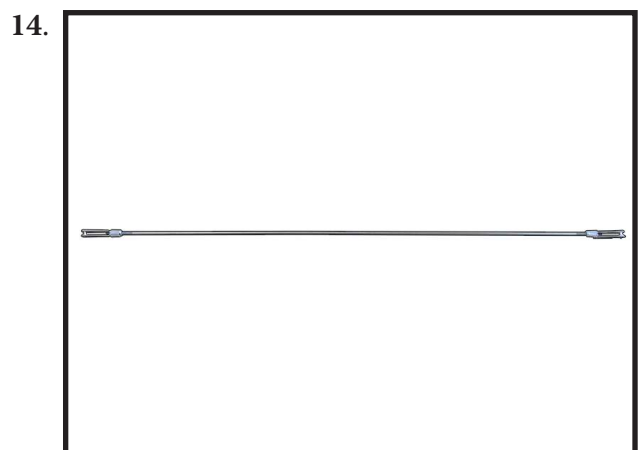
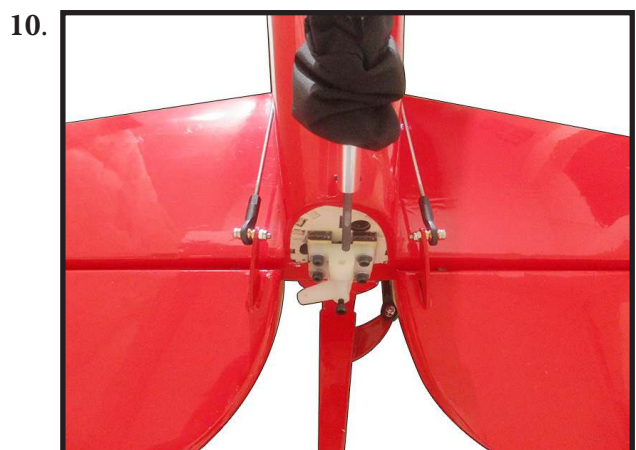
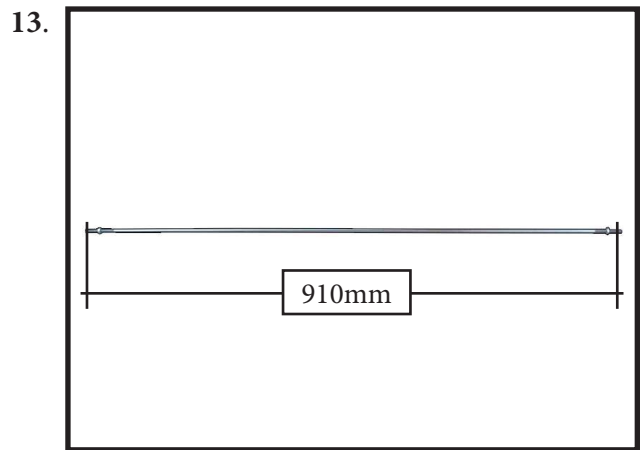
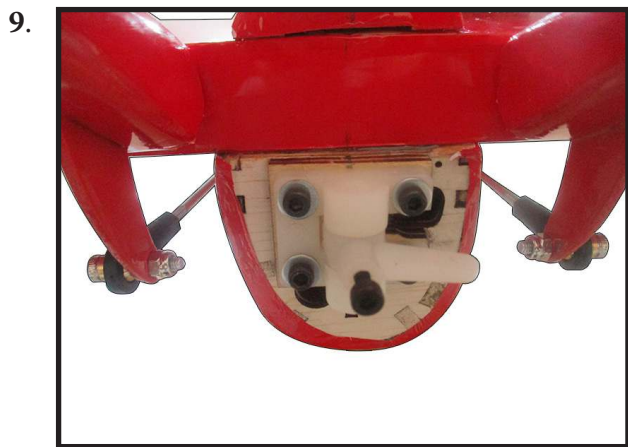
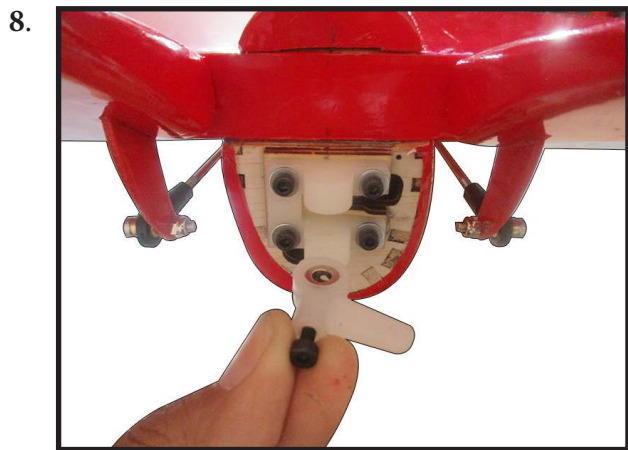
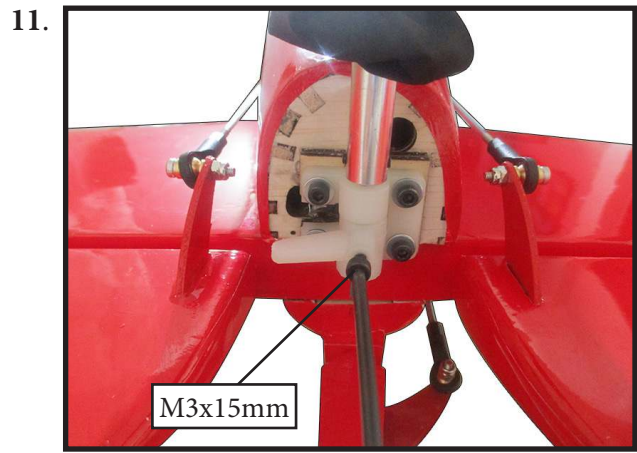
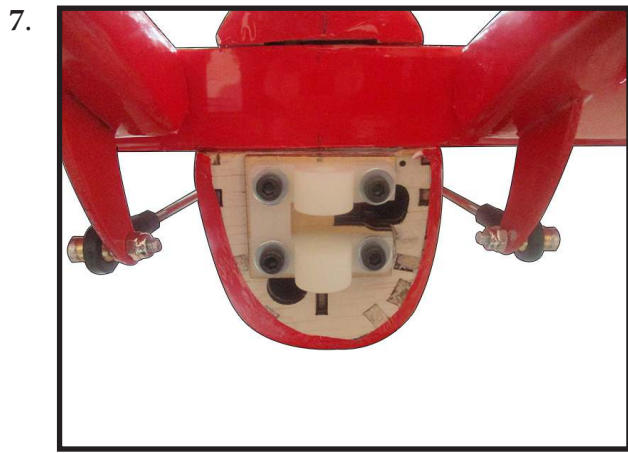

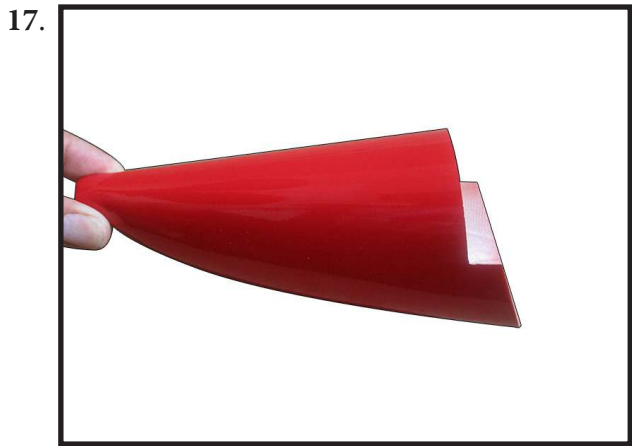
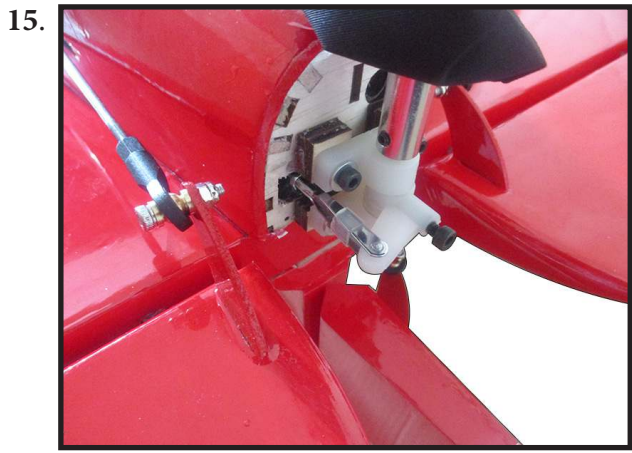

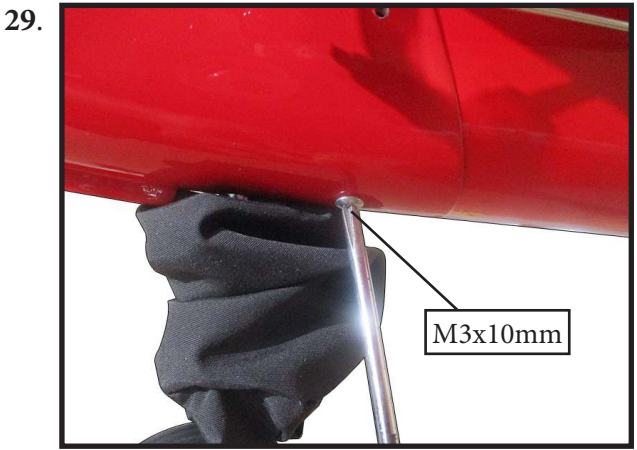
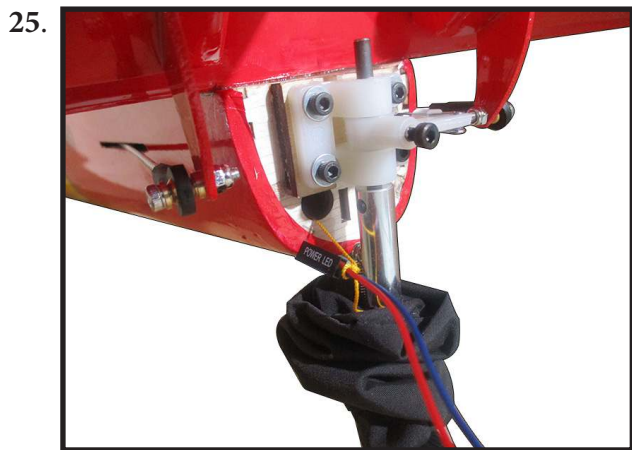
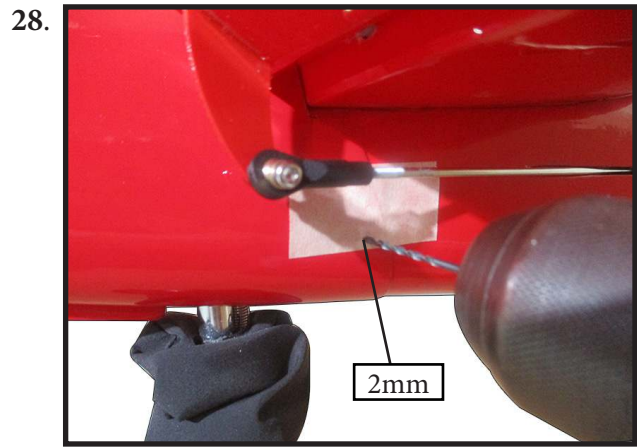
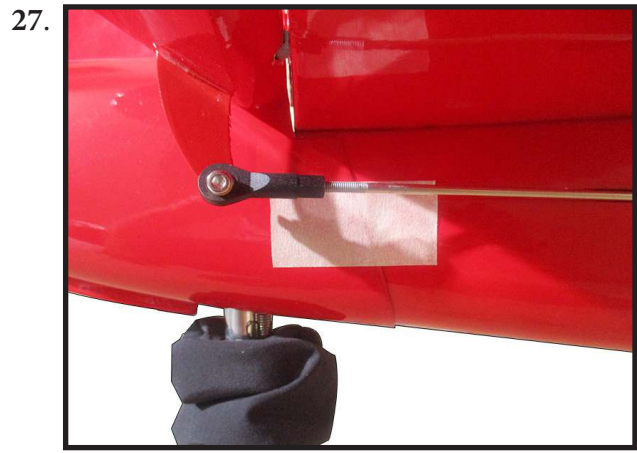
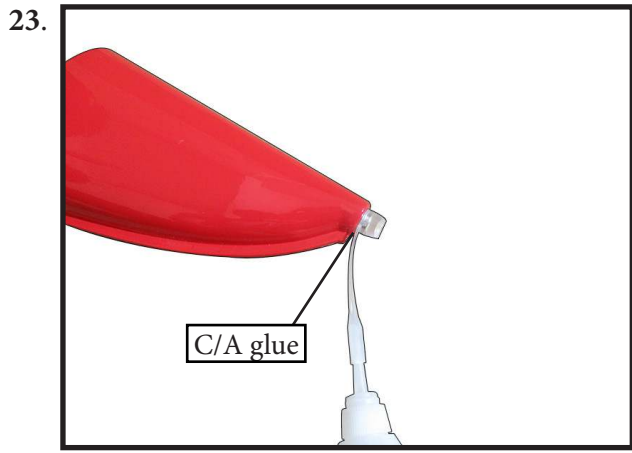

Install the plastic bar into the horizontal tail.

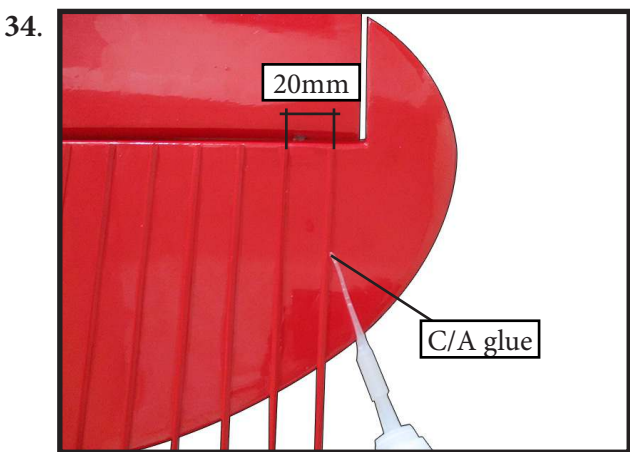
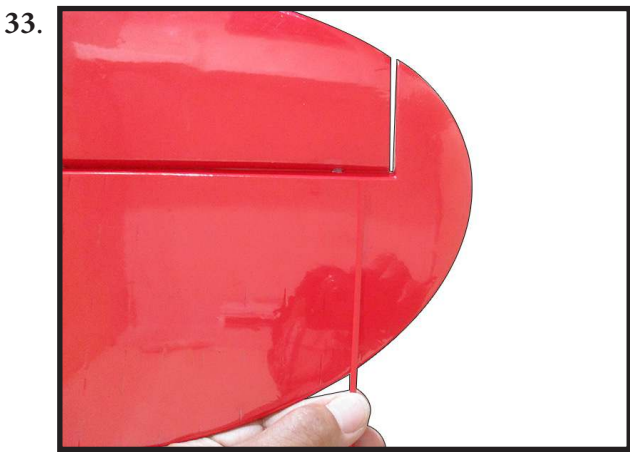
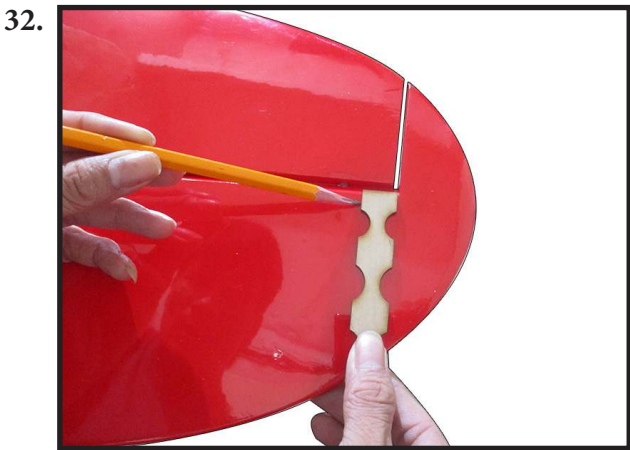
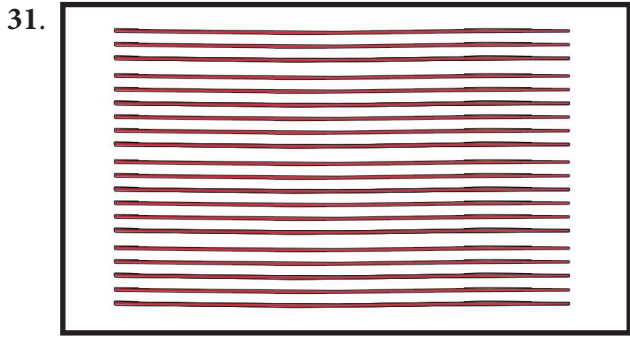

Install the plastic bar into the vertical tail.

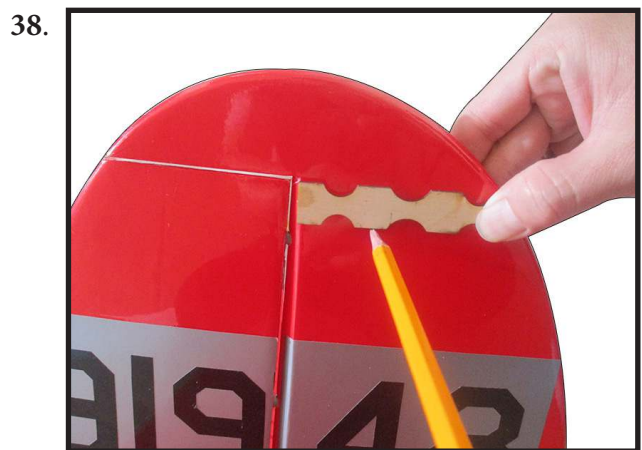
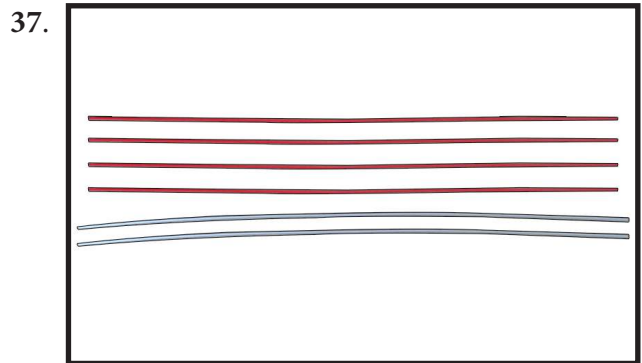

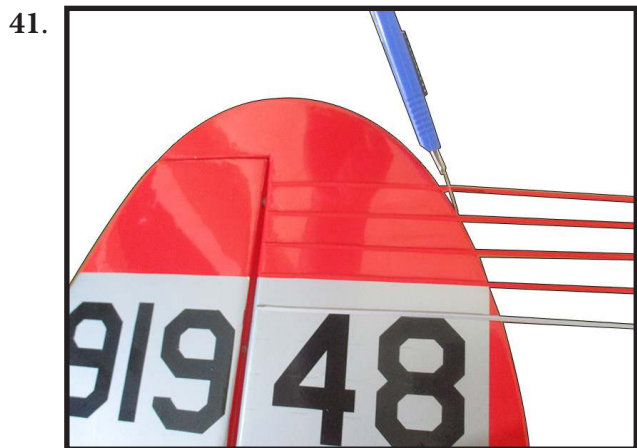
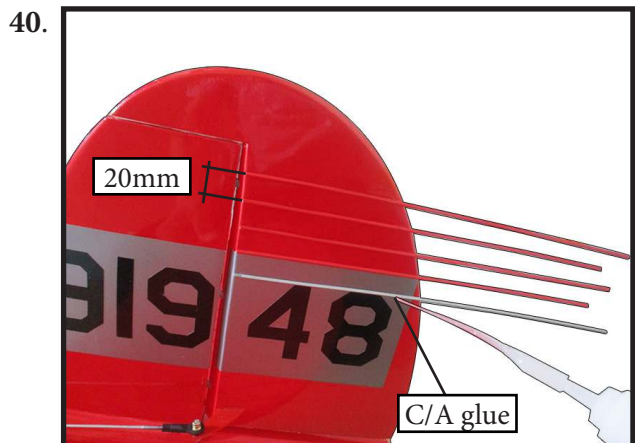

**DOUBLE SIDE VERTICAL TAIL
INSTALLATION**

Please see below pictures.

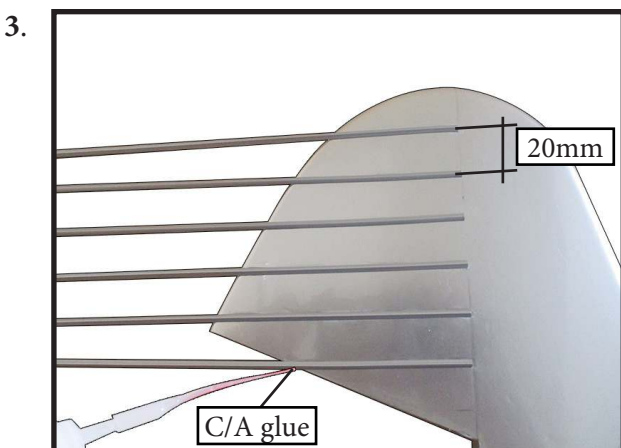
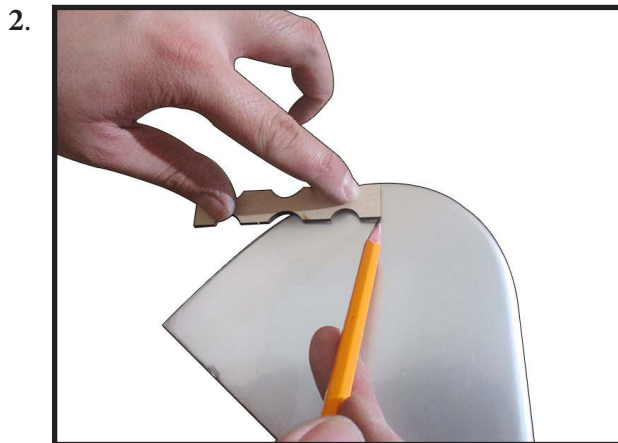

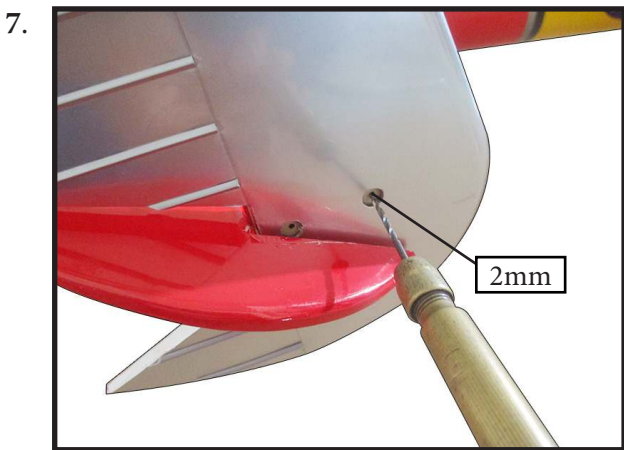
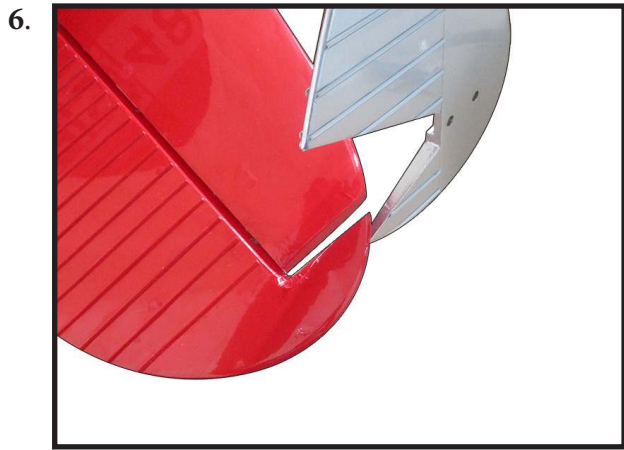
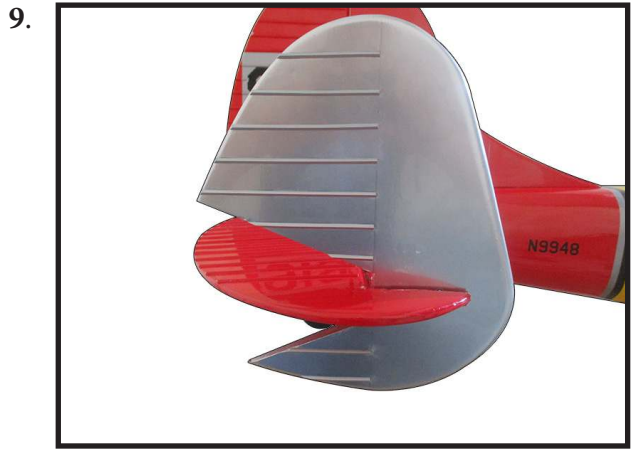
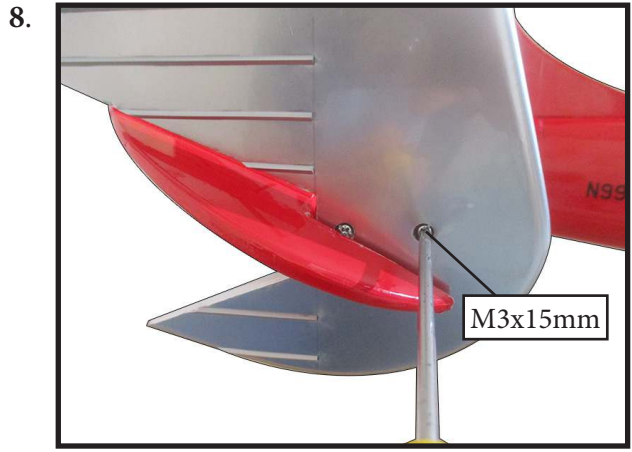
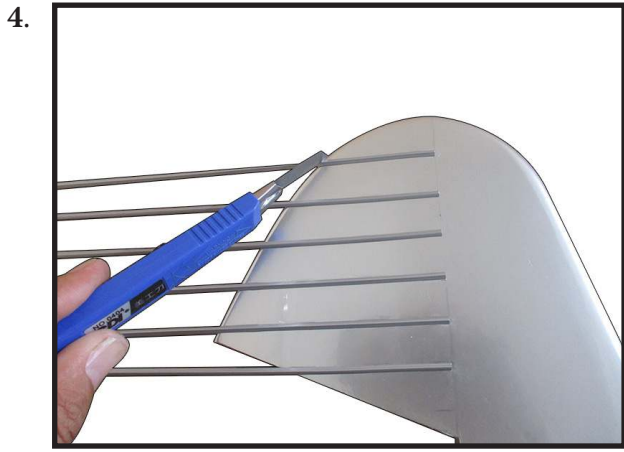

INSTALLING THE MAIN LANDING GEAR TO FUSELAGE

Locate items needed for landing gear installation.

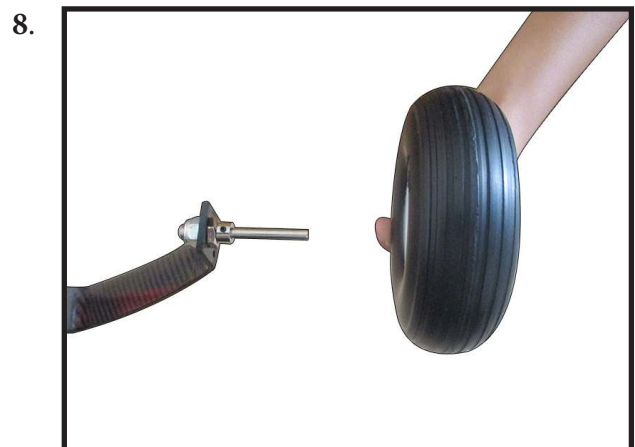
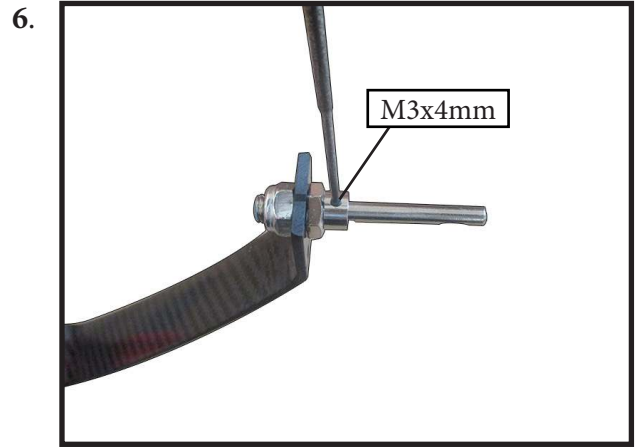
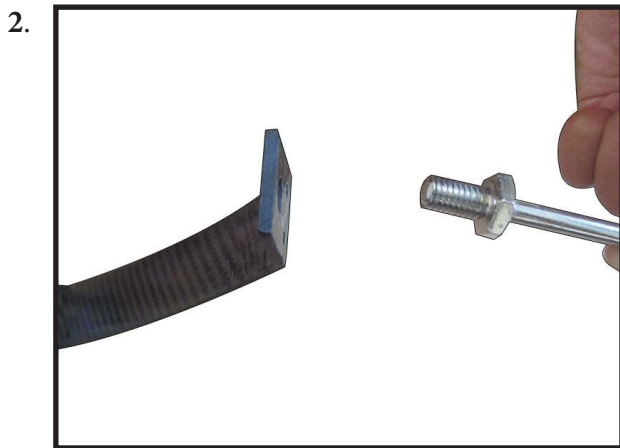
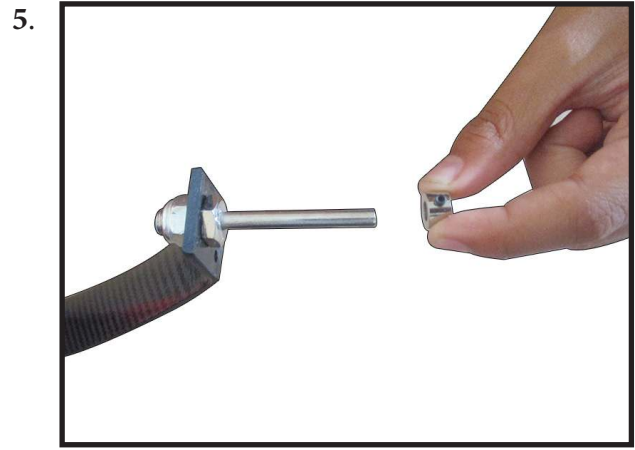

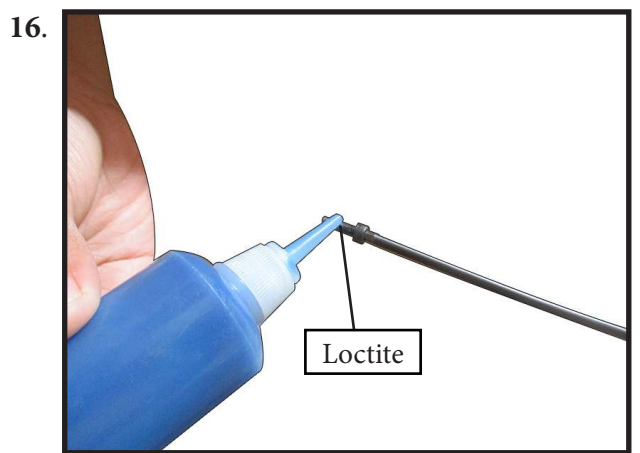
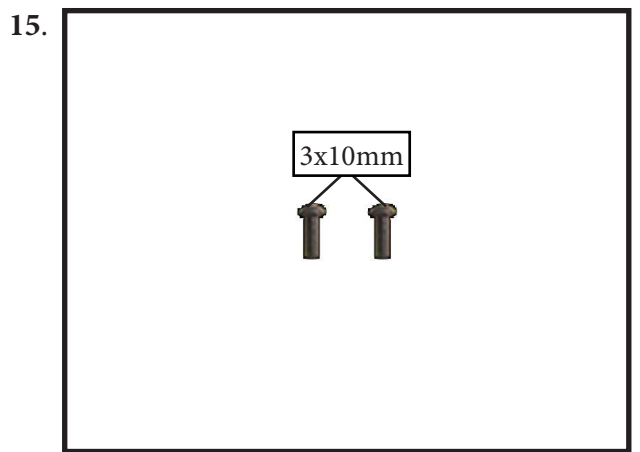
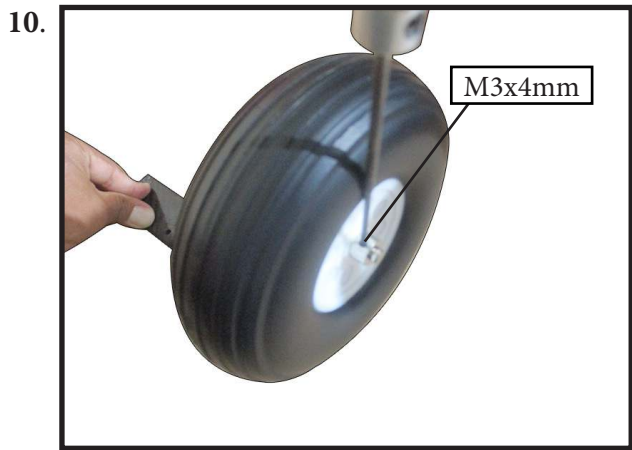
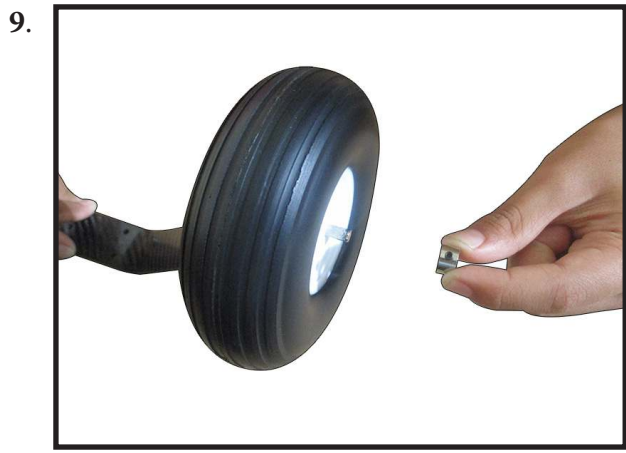

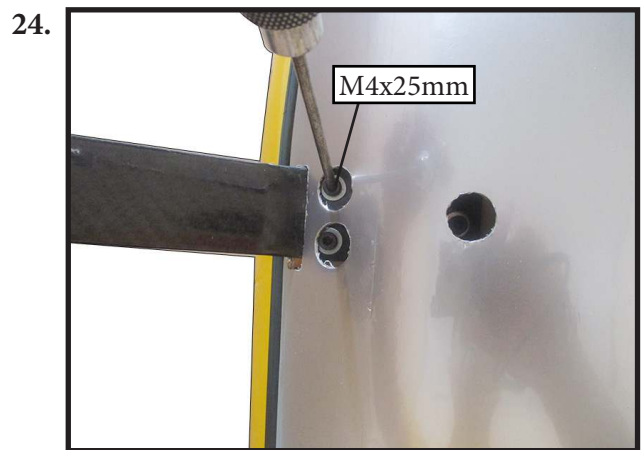
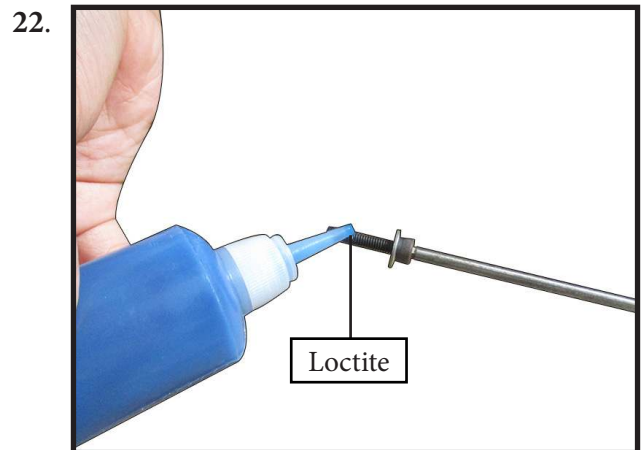
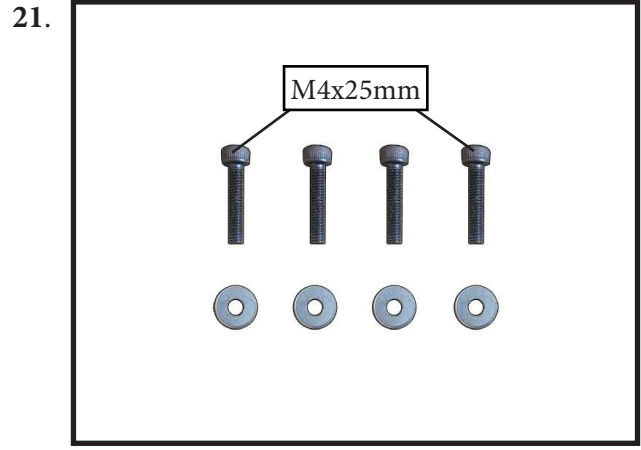

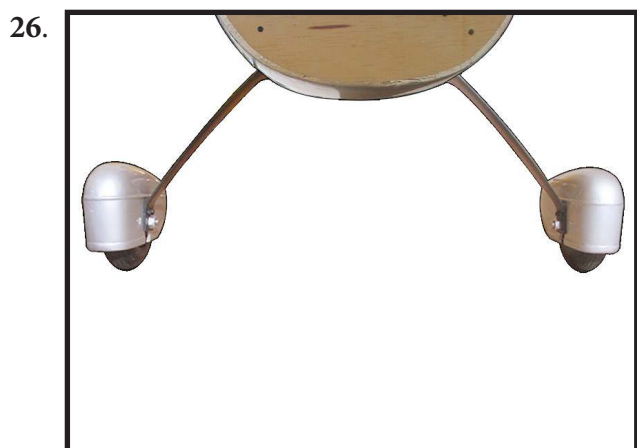
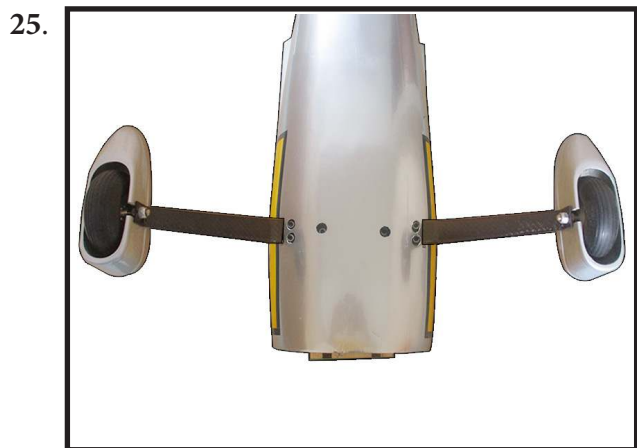

INSTALLING THE FUSELAGE SERVOS

 Because the size of servos differ, you may need to adjust the size of the precut opening in the mount. The notch in the sides of the mount allow the servo lead to pass through.

Install the rubber grommets and brass collets into all servos. Test fit the servos into the fuselage servo mounts.

Secure the servos with the screws provided with your radio system.

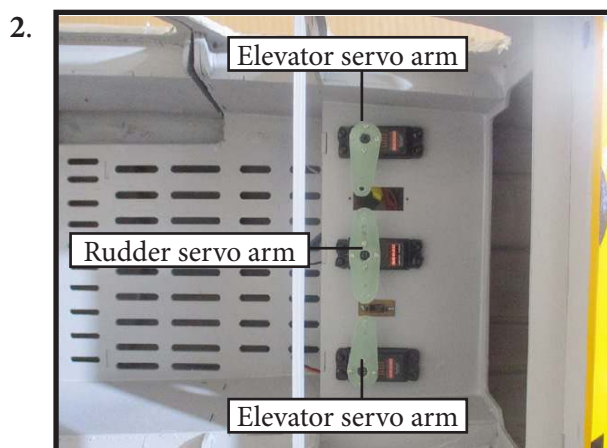
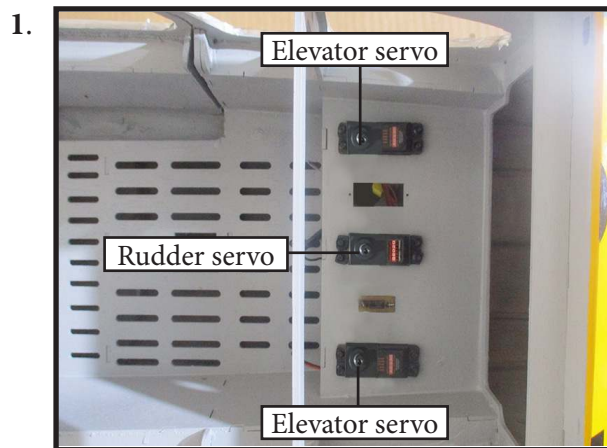

Maximum Servo spec.

Torque : 126.6 oz-in (9.11 kg-cm) @ 6.0V;
178 oz-in (12.82 kg-cm) @ 7.4V; 248 oz-in (17.86 kg-cm) @ 8.4V

FUEL TANK INSTALLATION



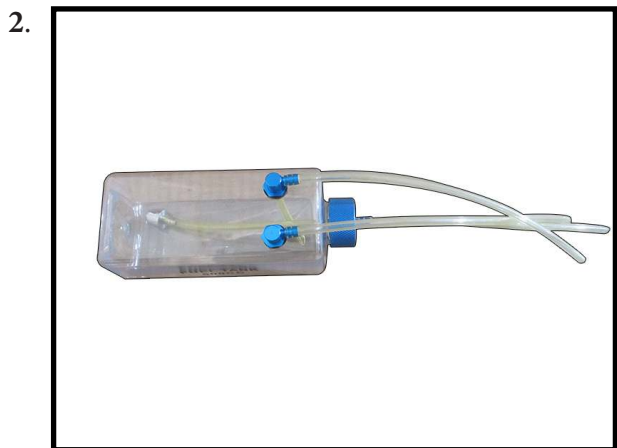

! *You should mark which tube is the vent and which is the fuel pickup when you attach fuel tubing to the tubes in the stopper. Once the tank is installed inside the fuselage, it may be difficult to determine which is which.*

Slide the fuel tank into the fuselage. Guide the lines from the tank through the hole in the firewall.

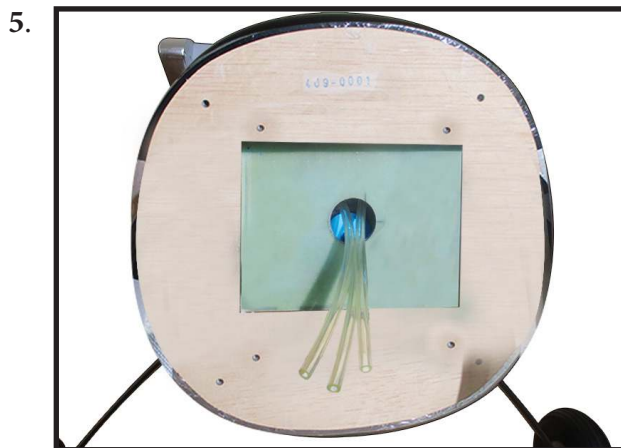
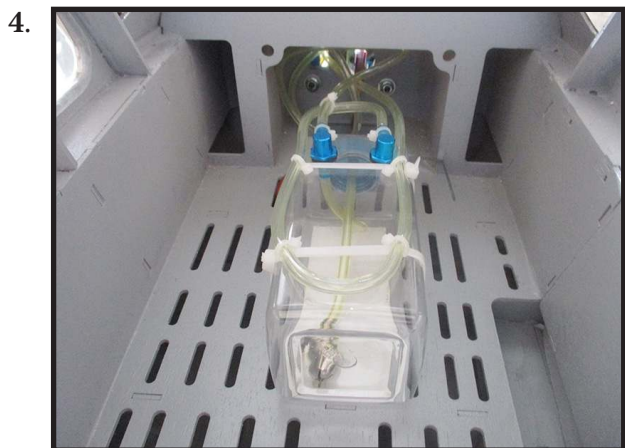

MOUNTING THE ENGINE

Please study the images below.

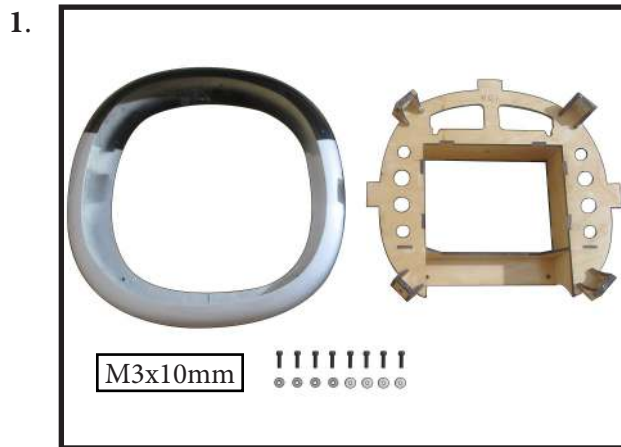

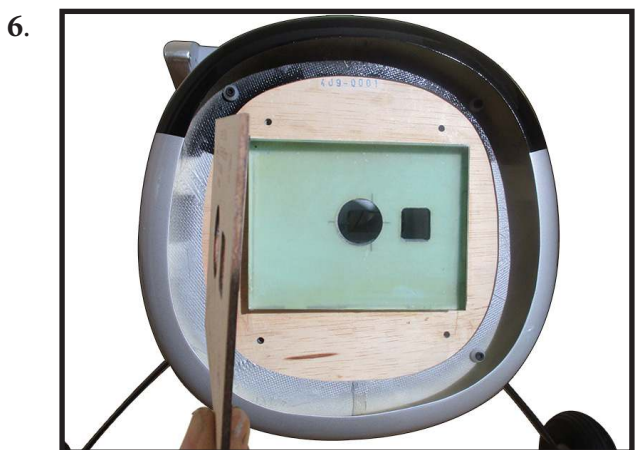
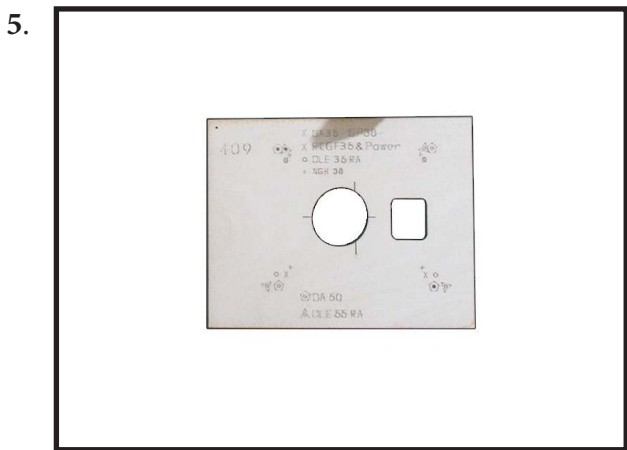
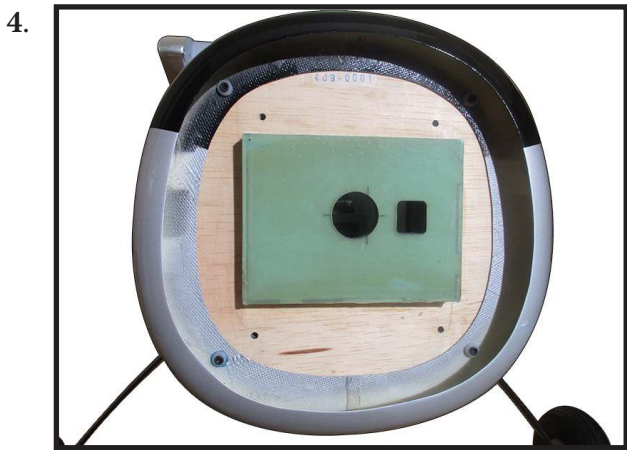
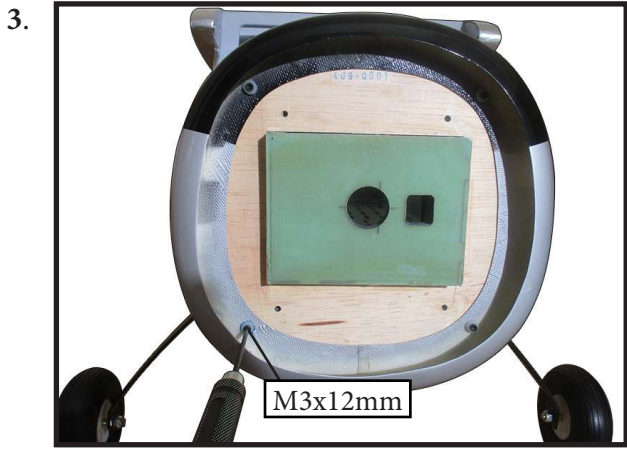

Locate the engine mounting in position on the firewall. Use a 5.2mm drill bit to drill the holes necessary to mount your particular engine choice.

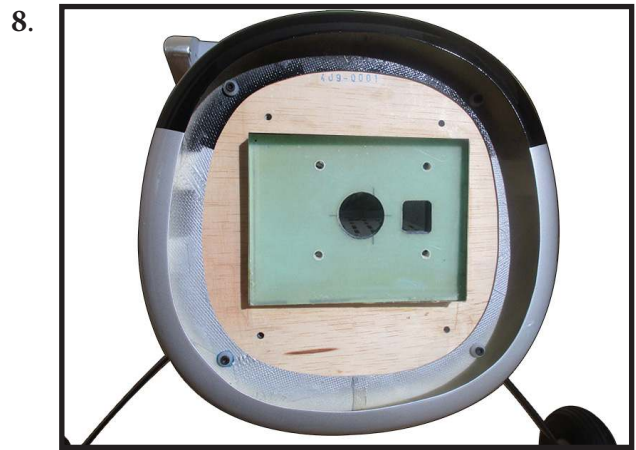
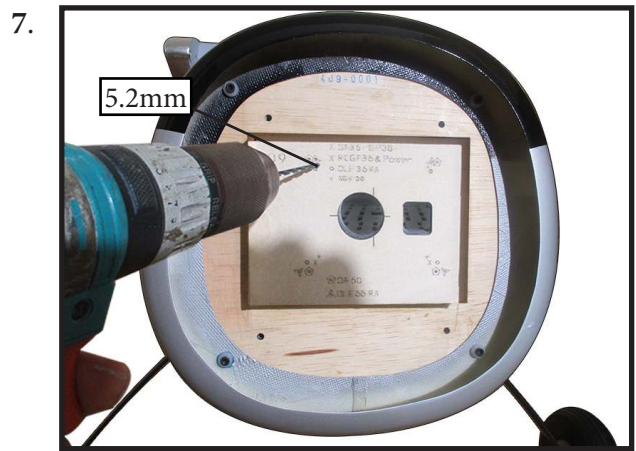

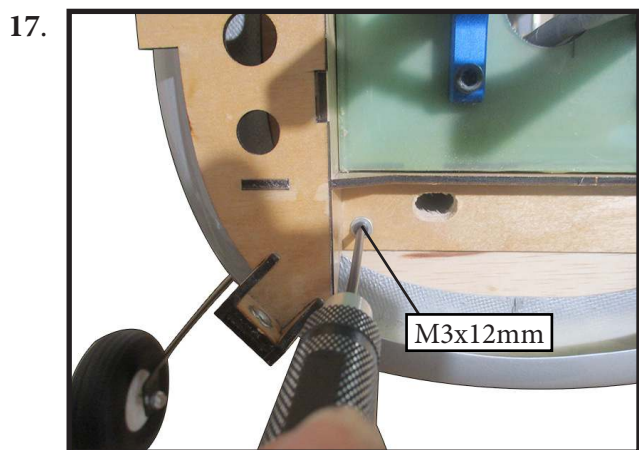
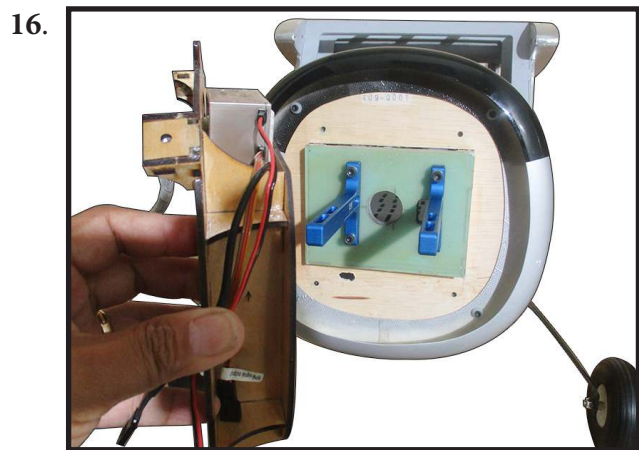
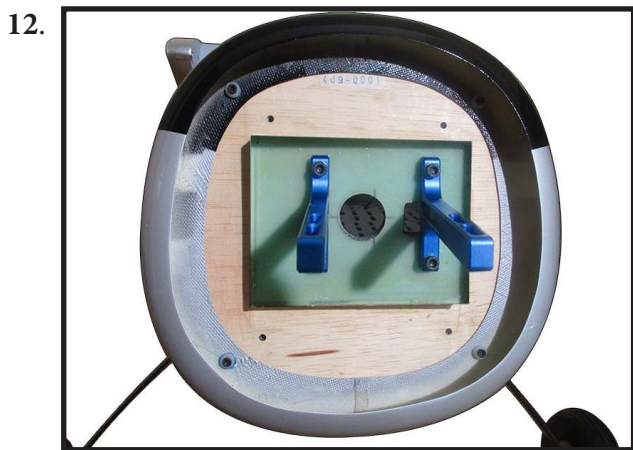
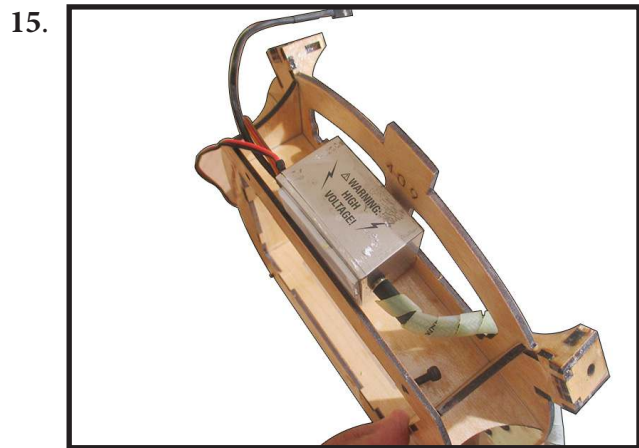
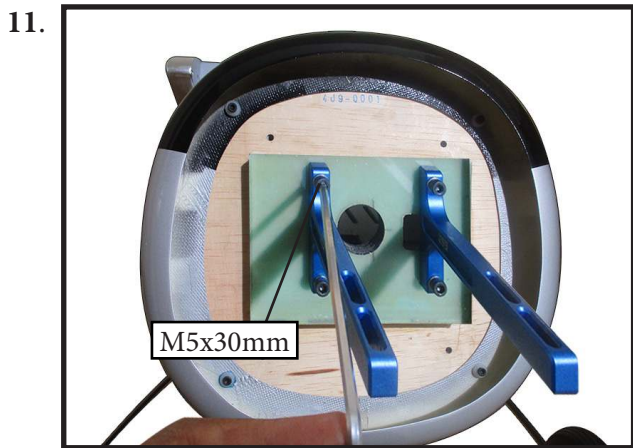
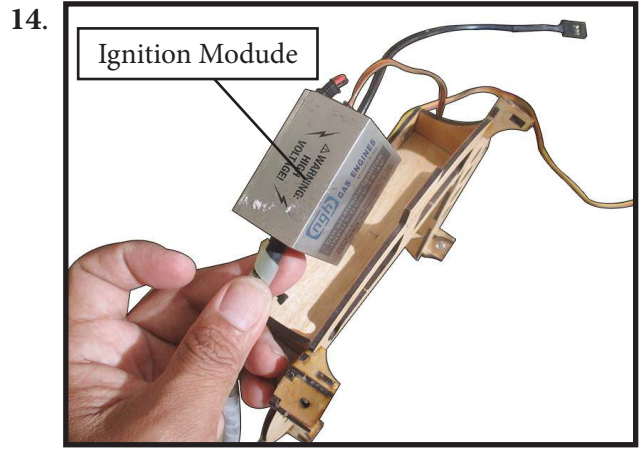
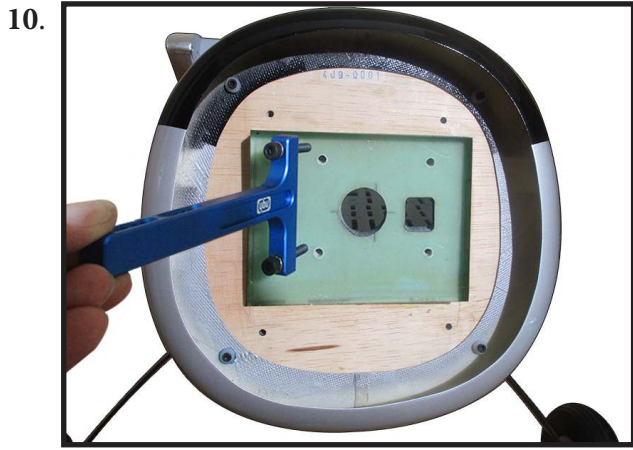

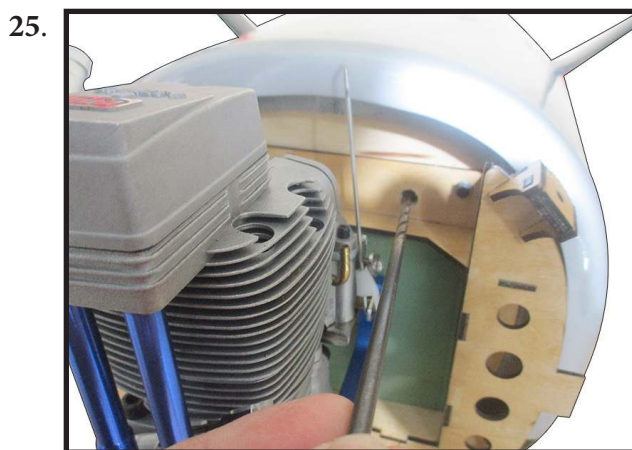
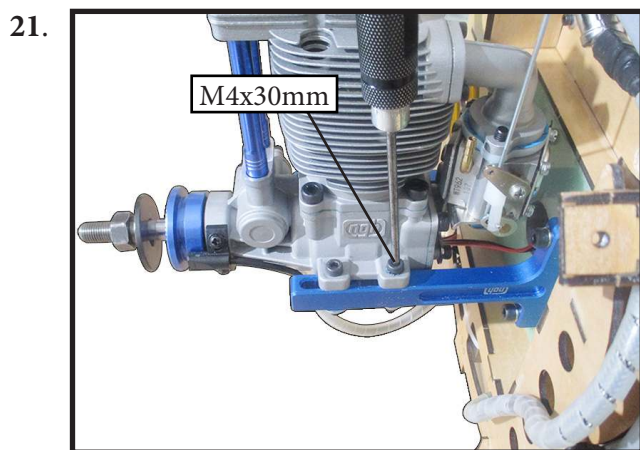
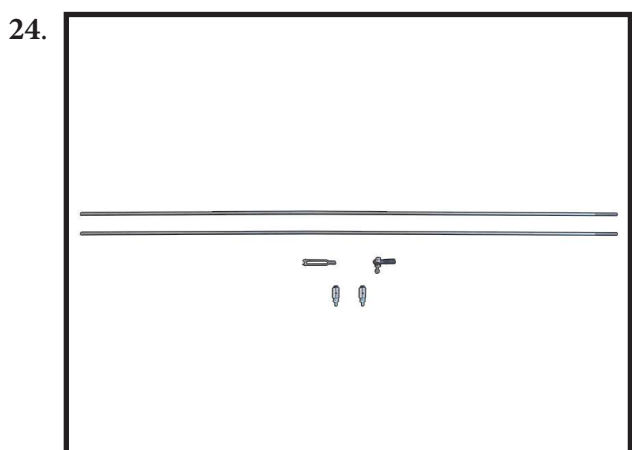
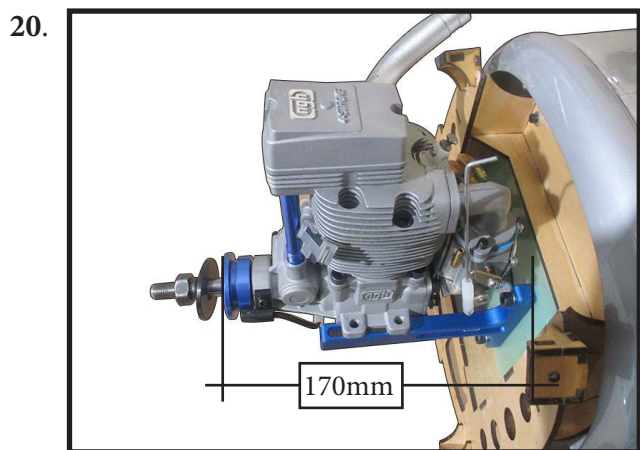
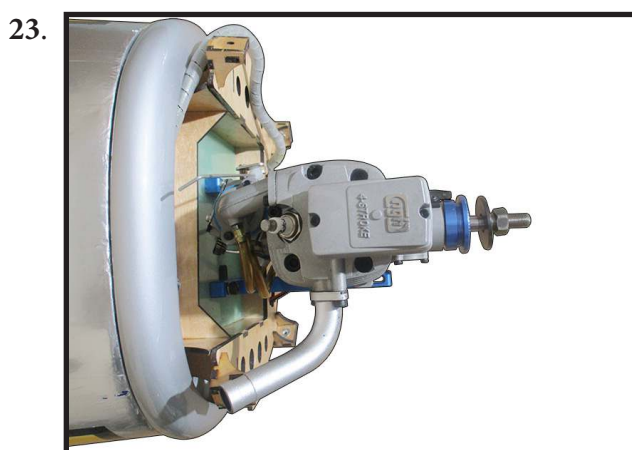
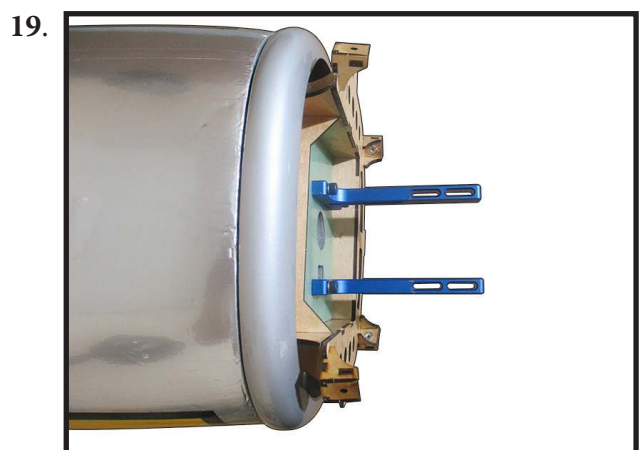
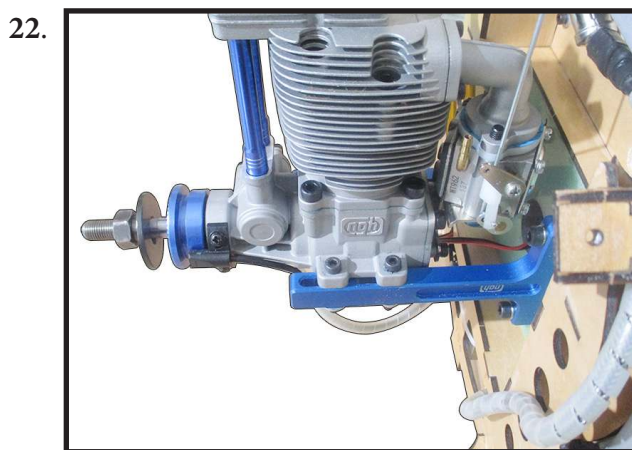
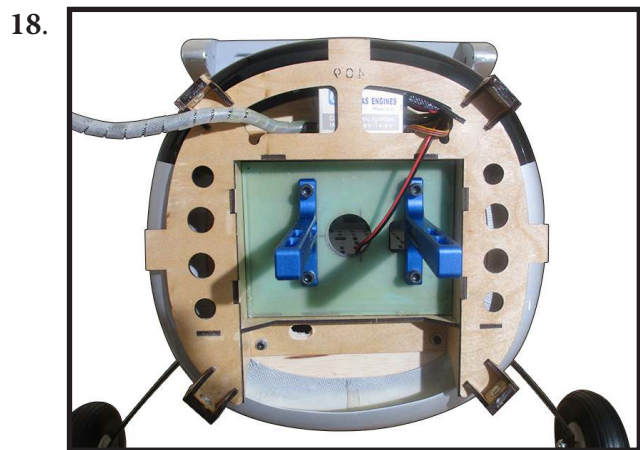

26.

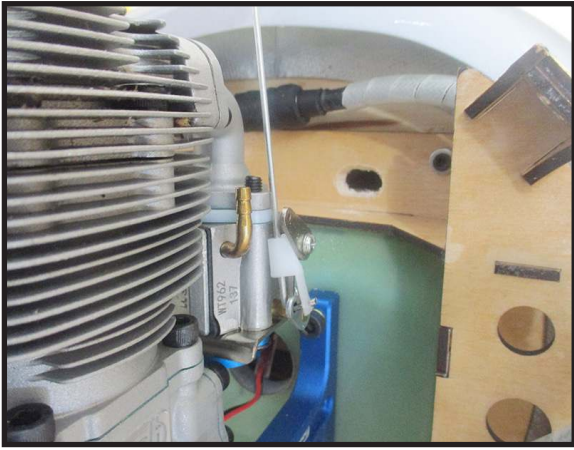

30.

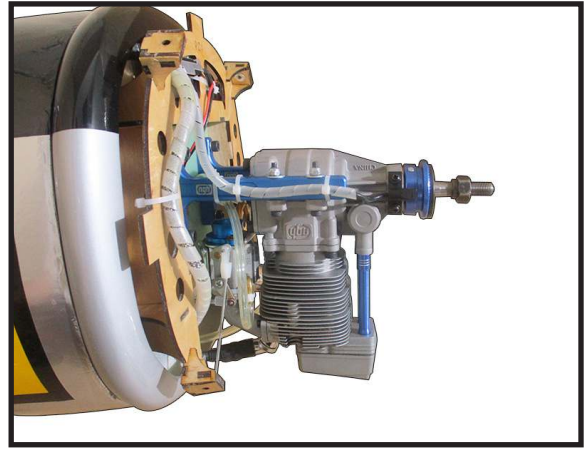

27.

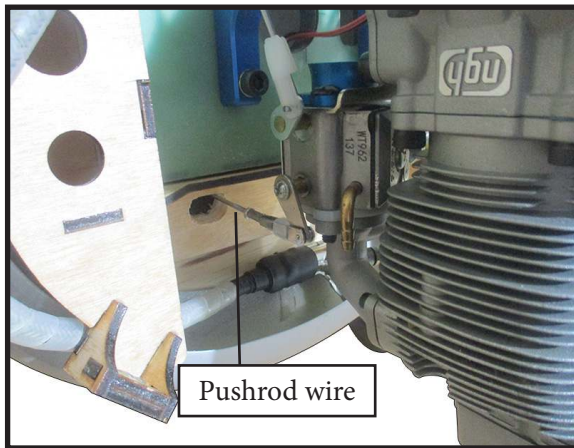

31.

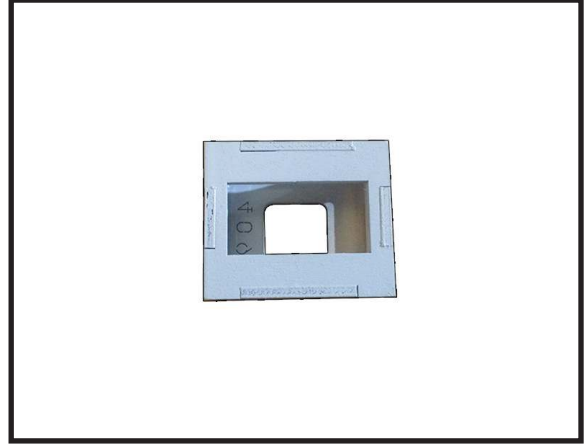

28.

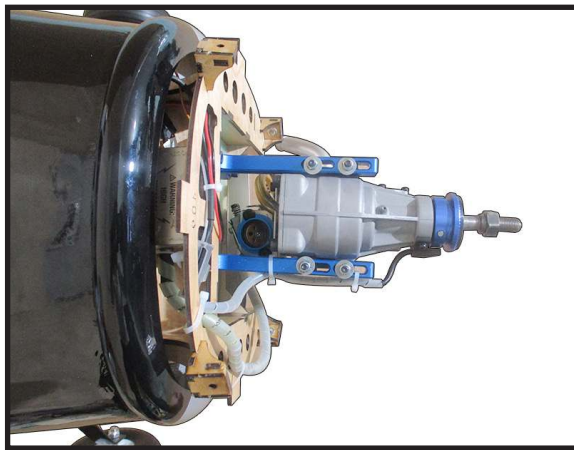

32.

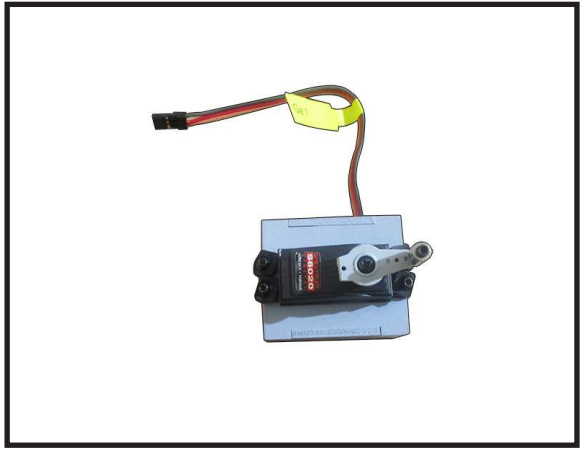

29.

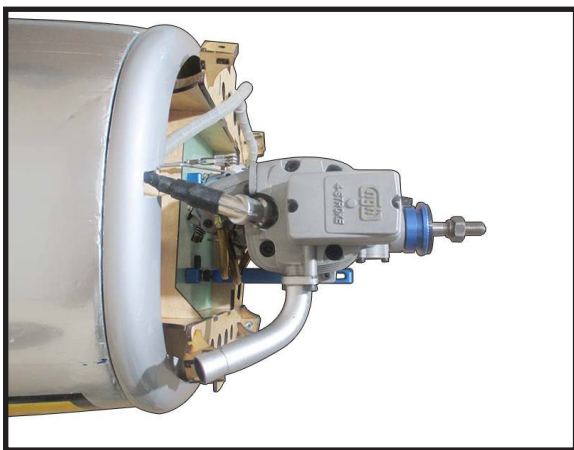

33.

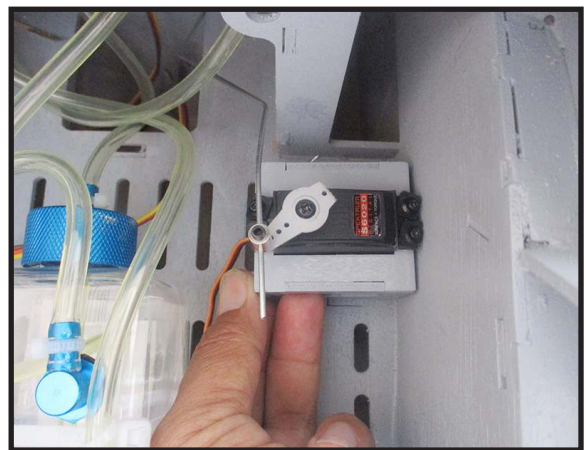



Reinstall the servo horn by sliding the connector over the pushrod wire. Center the throttle stick and trim and install the servo horn perpendicular to the servo center line.

COWLING

Please see Images below:

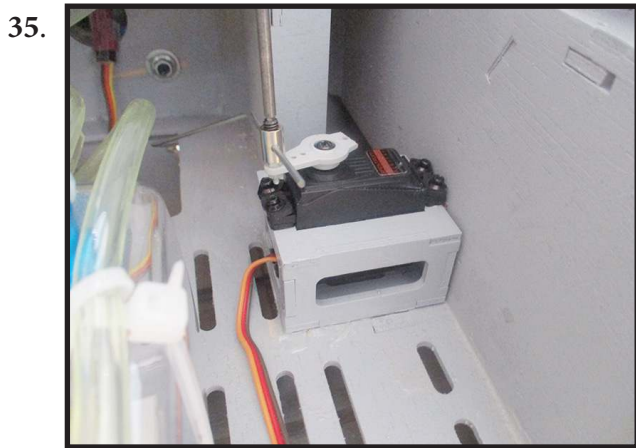

Move the throttle stick to the closed position and move the carburetor to closed.

Use a 3x10mm hex wrench to tighten the screw that secures the throttle pushrod wire. Make sure to use threadlock on the screw so it does not vibrate loose.







Tape the cowl to the fuselage using low-tack tape.

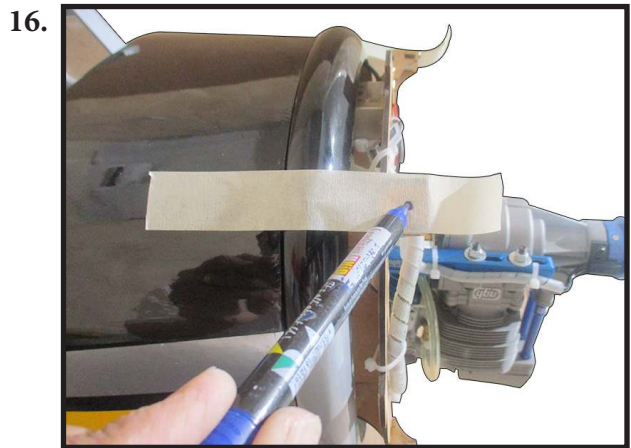

Use a drill and drill bit to drill the holes for the cowl mounting screws. Make sure the cowl position is correct before drilling each hole.

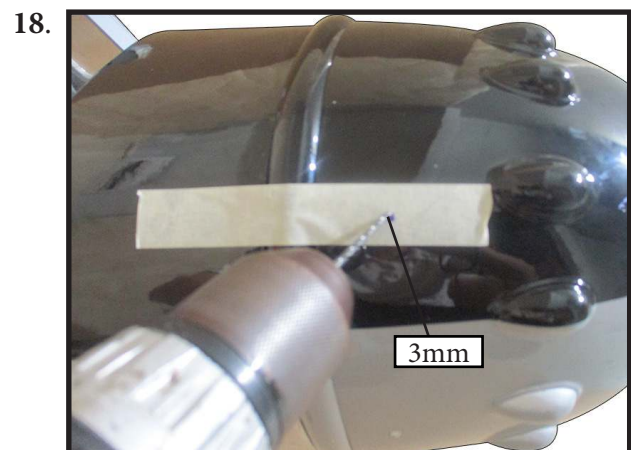

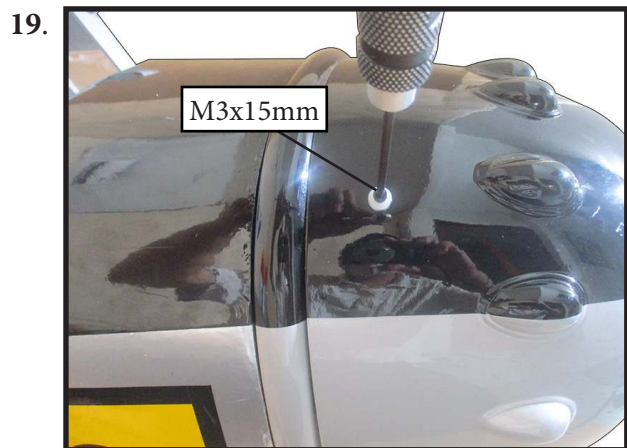

Because of the size of the cowling, it may be necessary to use a needle valve extension for the high speed needle valve. Make this out of sufficient length 1.5mm wire and install it into the end of the needle valve. Secure the wire in place by tightening the set screw in the side of the needle valve.

ELECTRIC POWER CONVERSION

Locate the items necessary to install the electric power conversion included with your model.

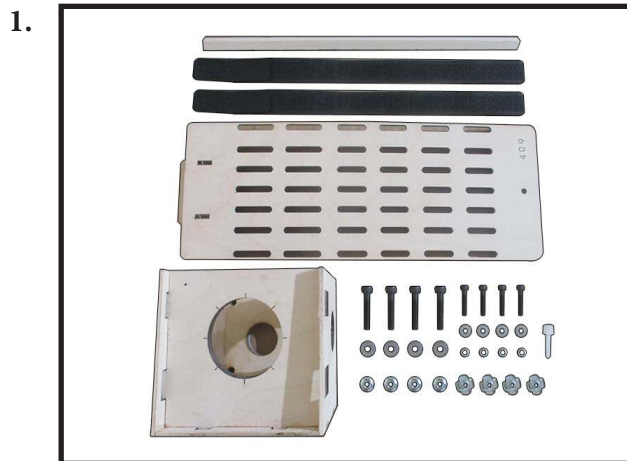

Recommend the items necessary to install the electric power conversion parts included with your model.

- Motor: Recommend : 60XX motor size or more.

- Propellers: 18x12 or 19x10.



Attach the electric motor box to the firewall centered with the cross lines drawn on the electric motor box and firewall. Using M5x30mm to secure the motor box to the firewall. Please see pictures below.



2.



Attach the motor mount to the front of the electric motor box using four 5mm blind nut, four M5x30mm hex head bolts to secure the motor. Please see picture shown.

3.



4.



5.

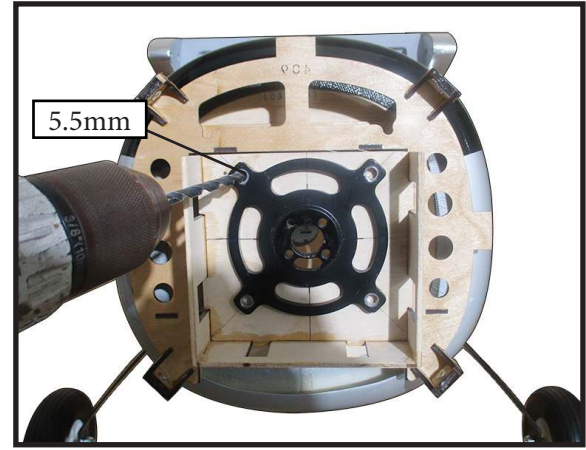

Then, use 5.5mm drill bit to enlarge the holes on the electric motor box.

6.

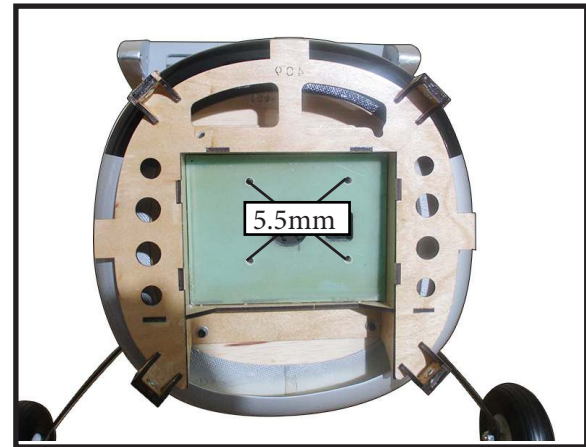

7.

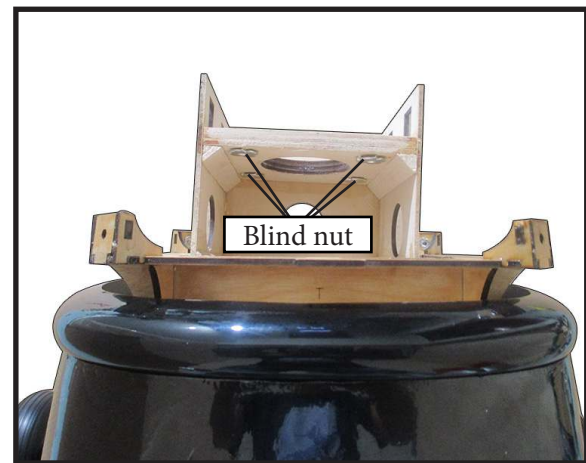

Attach the motor to the front of the electric motor box using four 5mm blind nut, four M4x20mm hex head bolts to secure the motor. Please see picture shown.

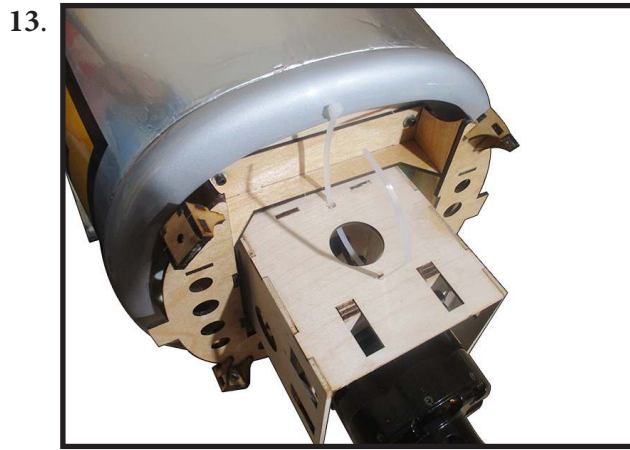
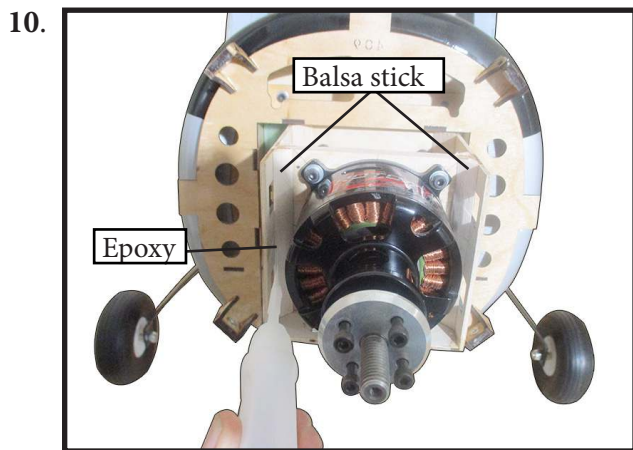
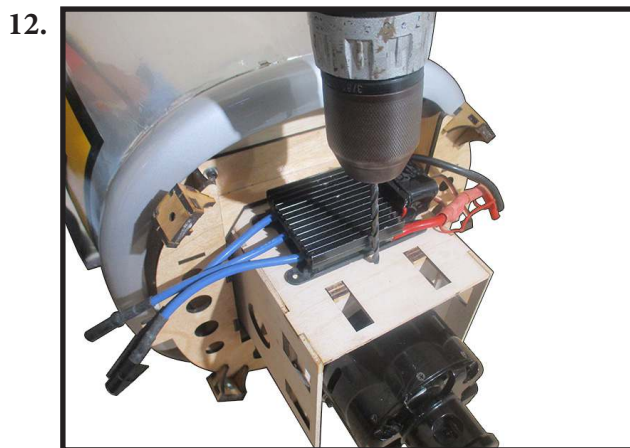
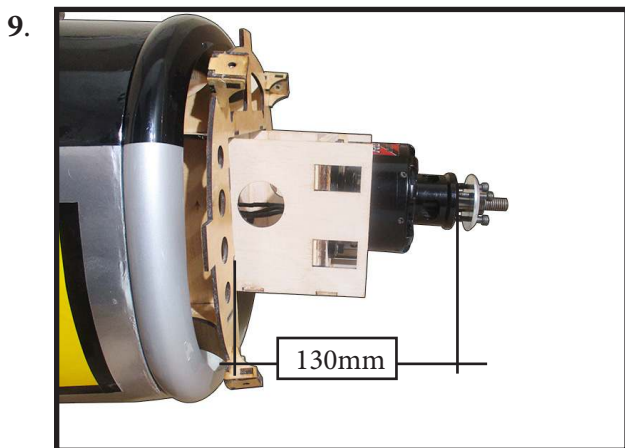
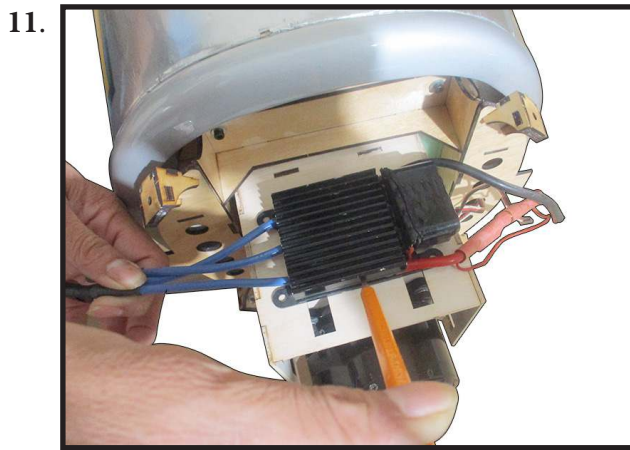
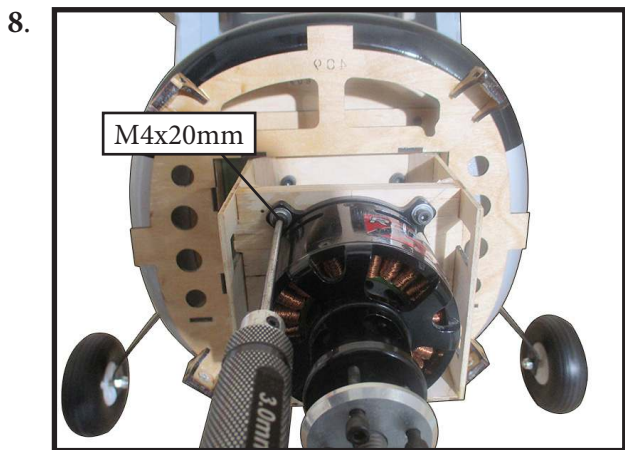

Attach the speed control to the side of the motor box using two-sided tape and tie wraps. Connect the appropriate leads from the speed control to the motor. Make sure the leads will not interfere with the operation of the motor.

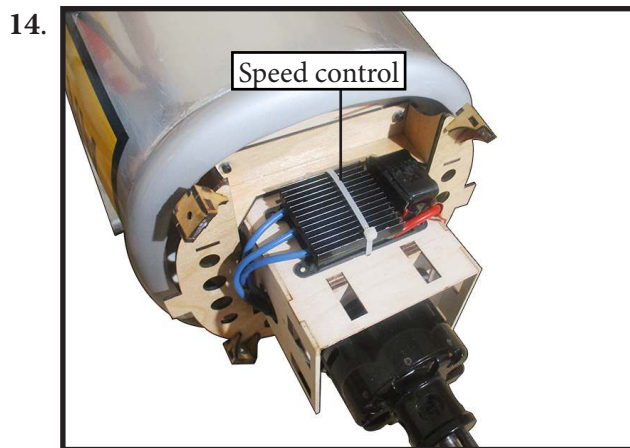

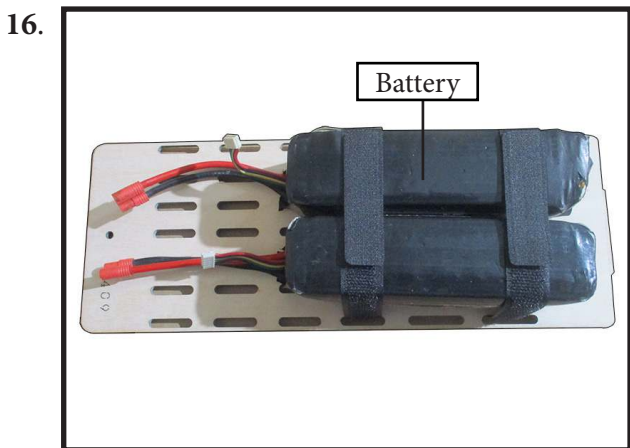
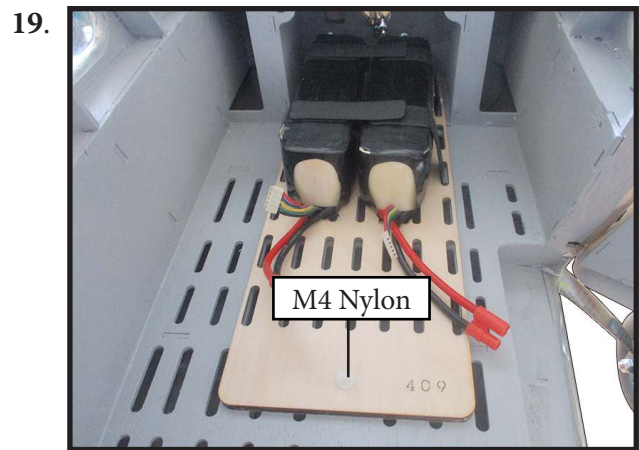

INSTALLING THE SPINNER

Install the spinner backplate, propeller and spinner cone.



 The propeller should not touch any part of the spinner cone. If it does, carefully trim spinner cone opening until propeller no longer comes in contact with it.

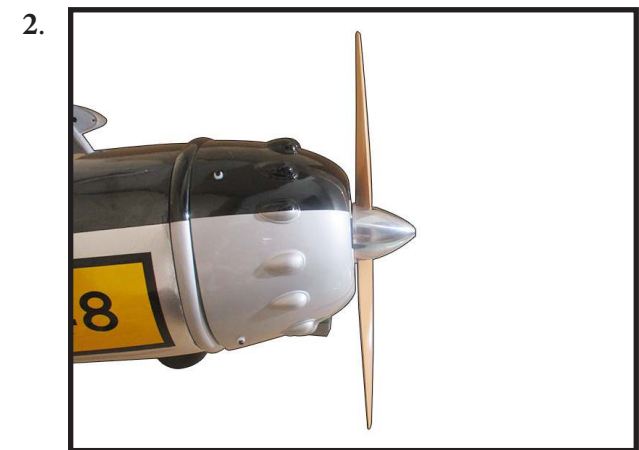
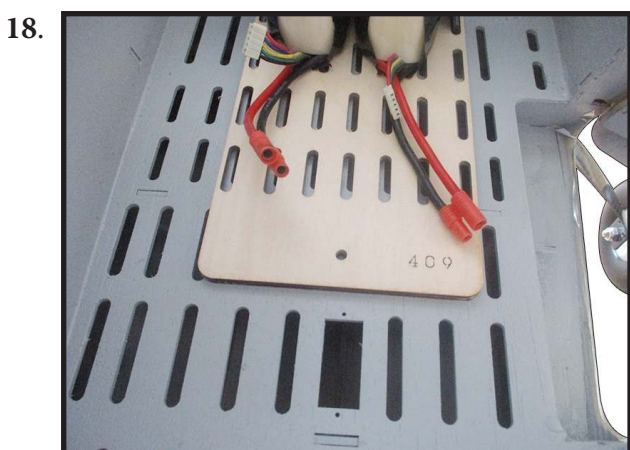

INSTALL LED BULB ON BODY BELLY

Parts requirement. See pictures below.

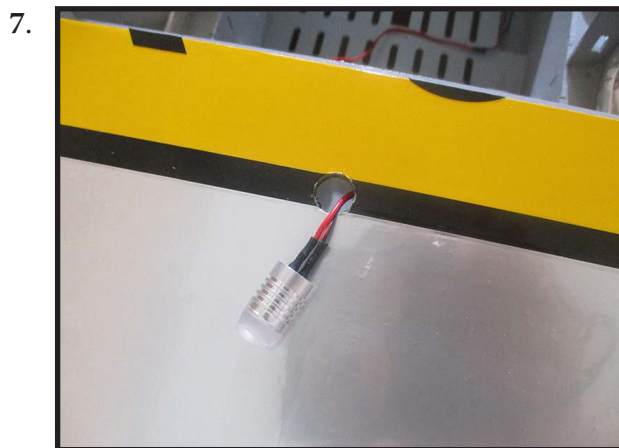
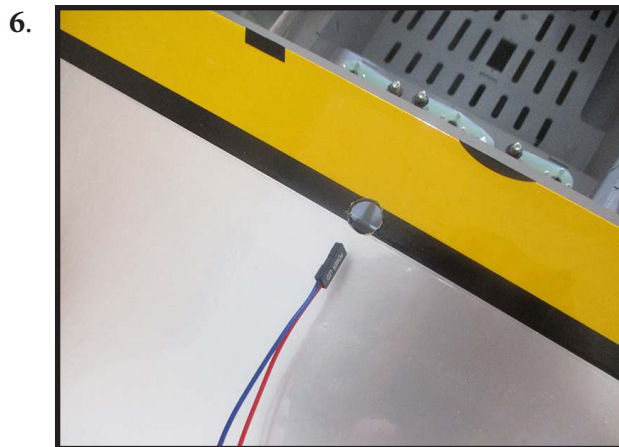
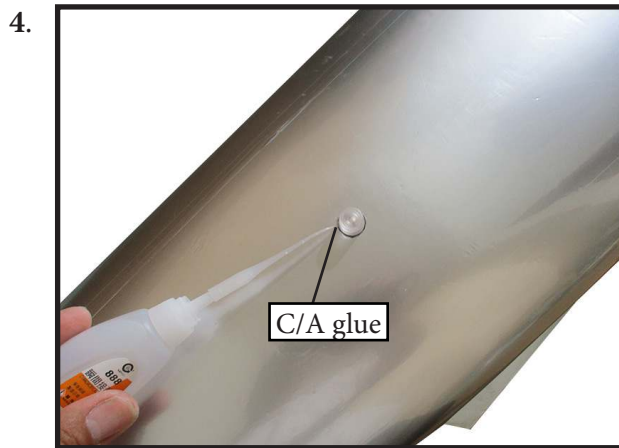
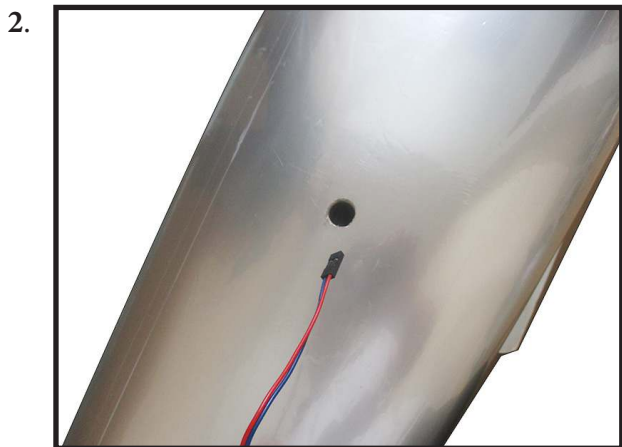
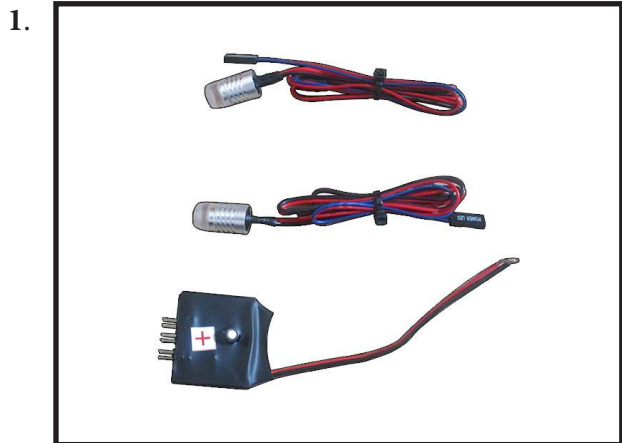

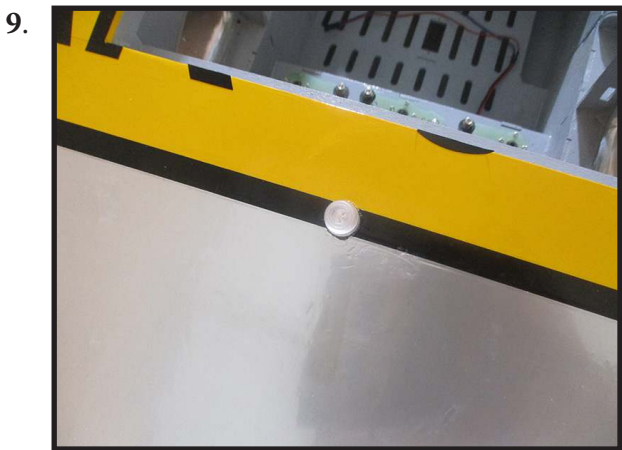
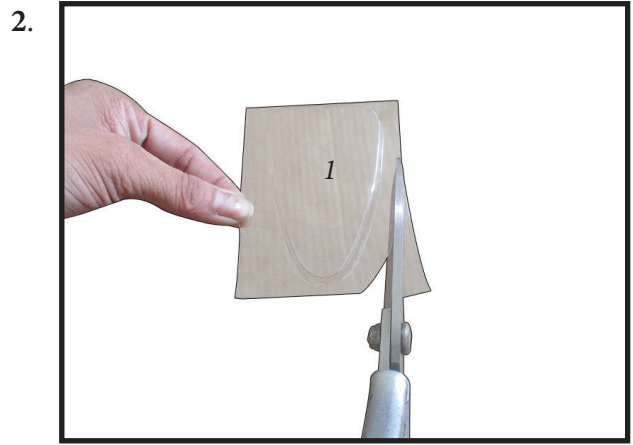
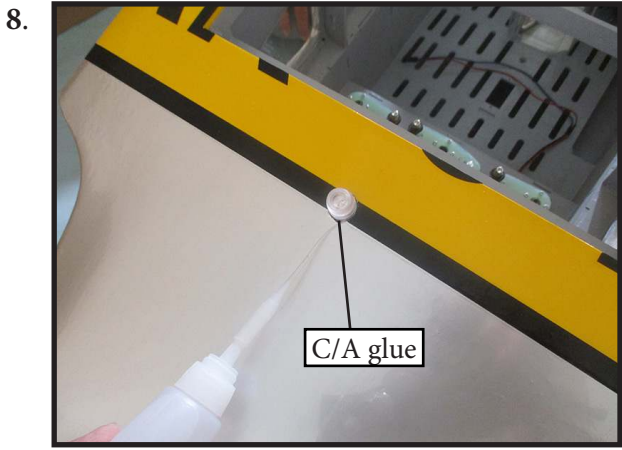

INSTALL THE WINDOW

Parts requirement. See pictures below.

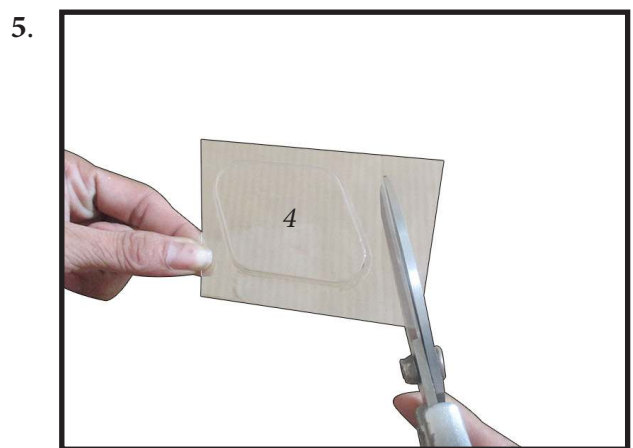
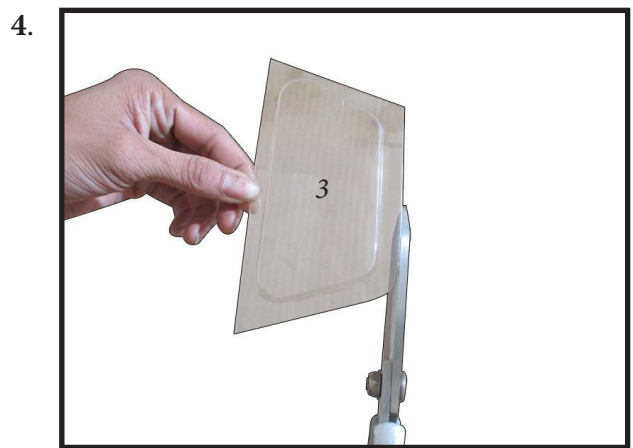

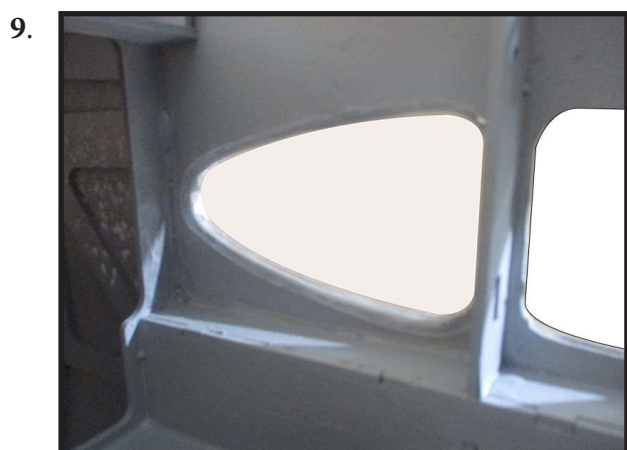
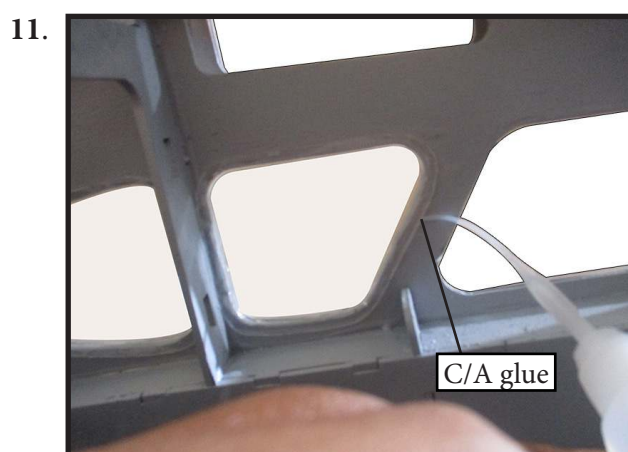
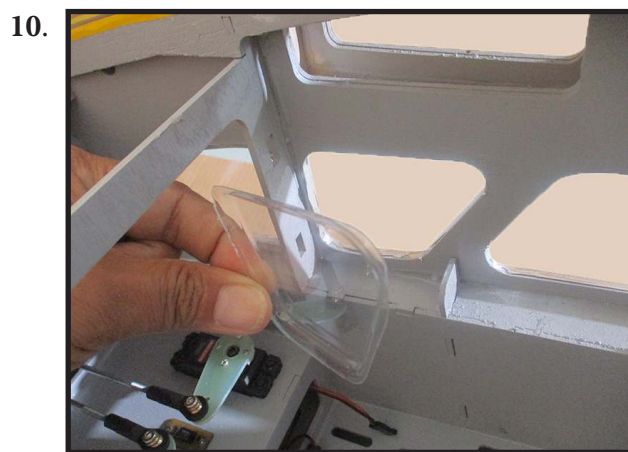
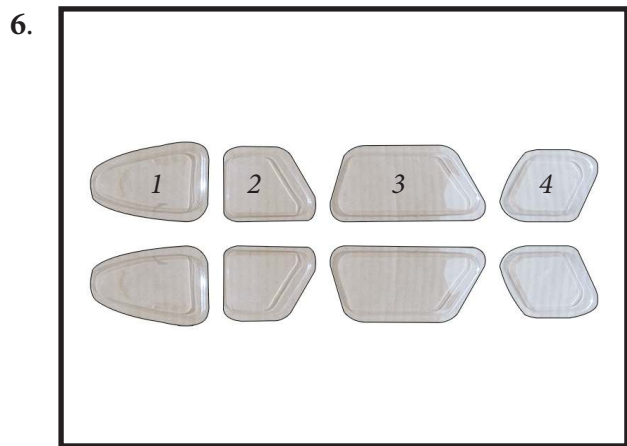

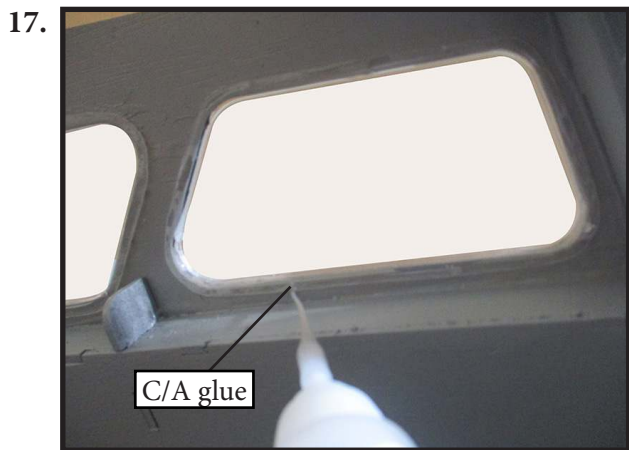
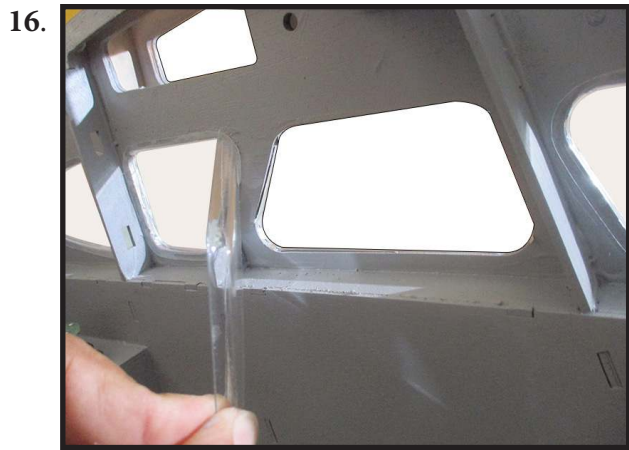
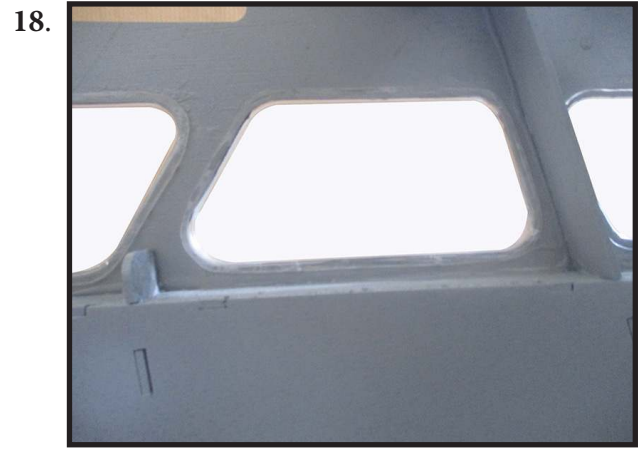
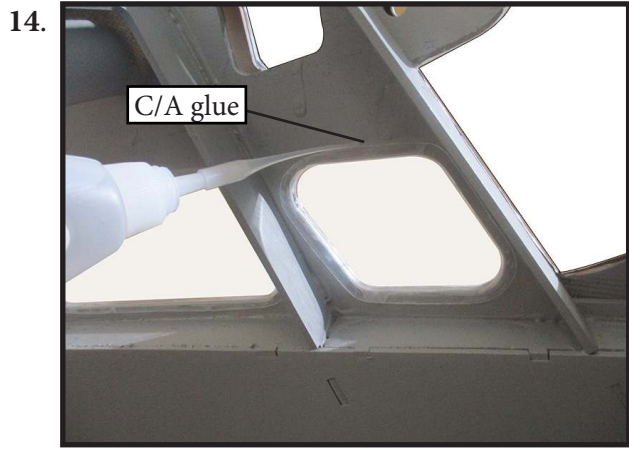

INSTALLATION COCKPIT AND CANOPY

Locate items necessary to install.

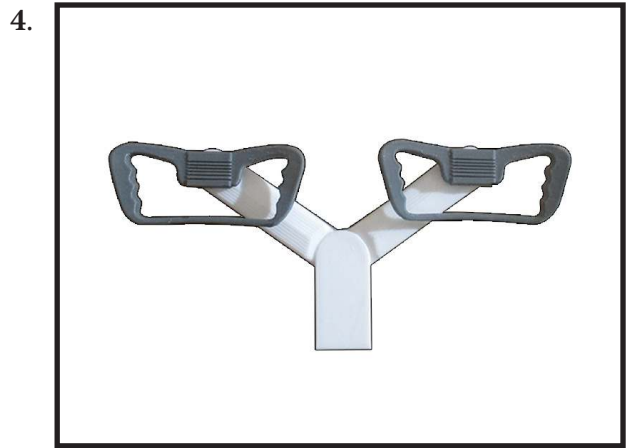
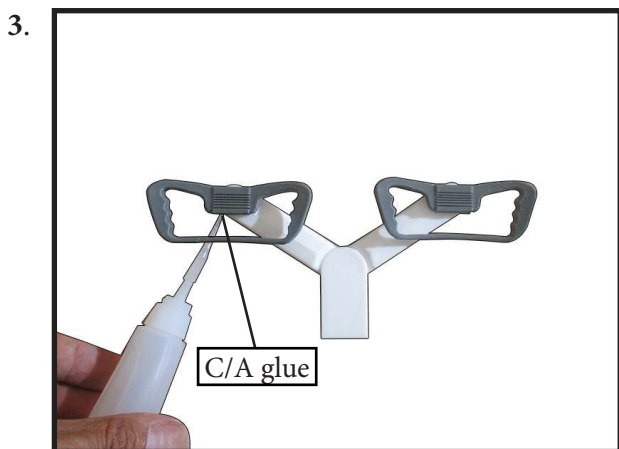
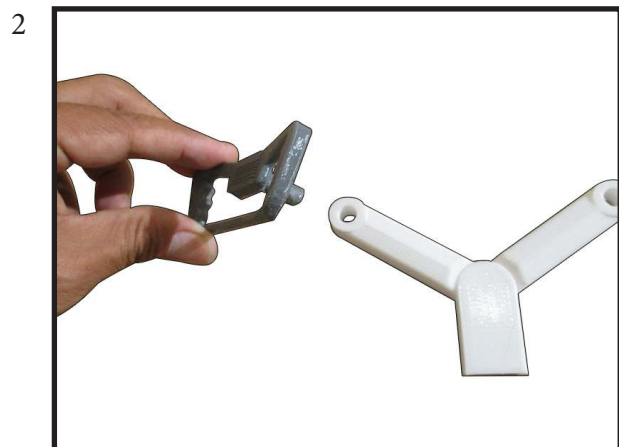
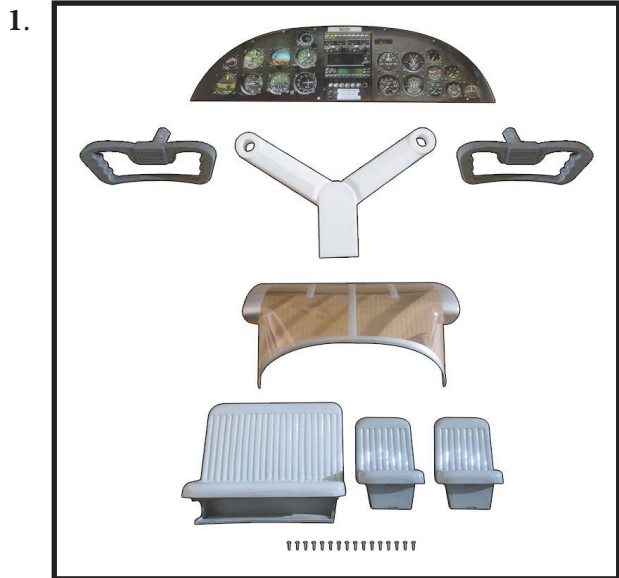

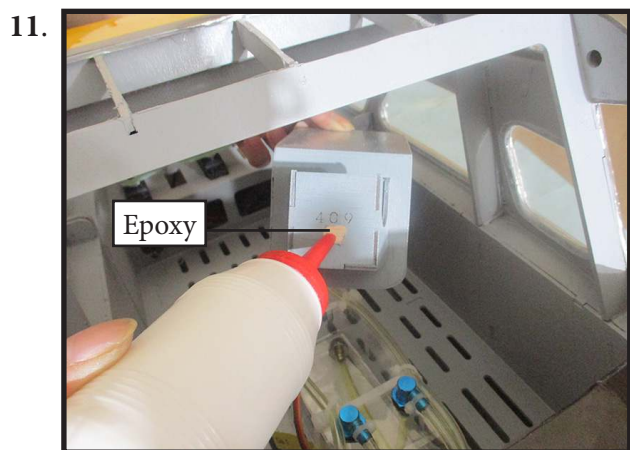
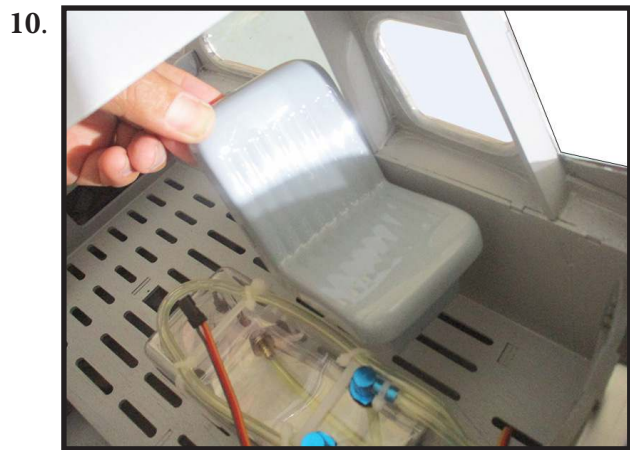
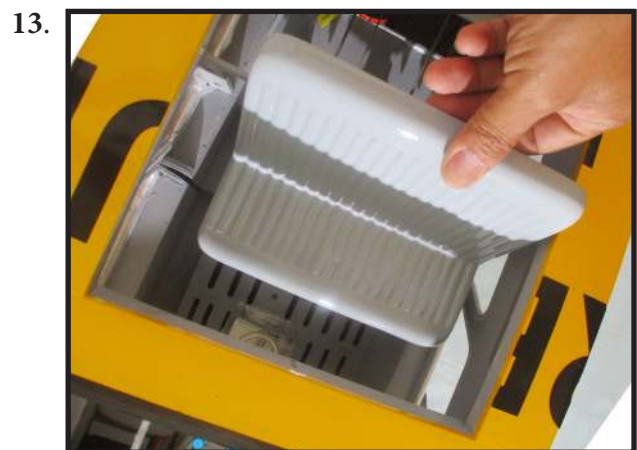
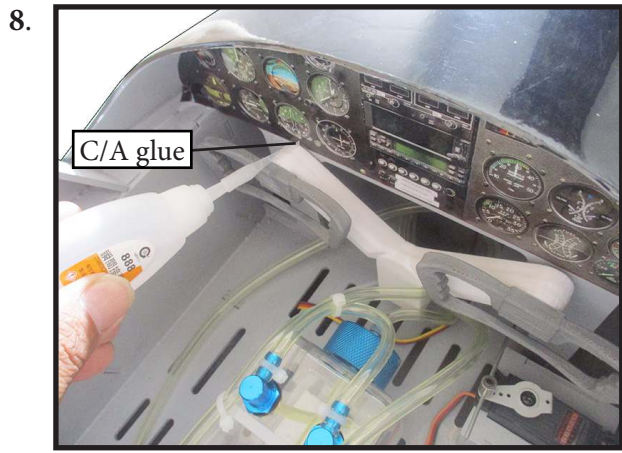

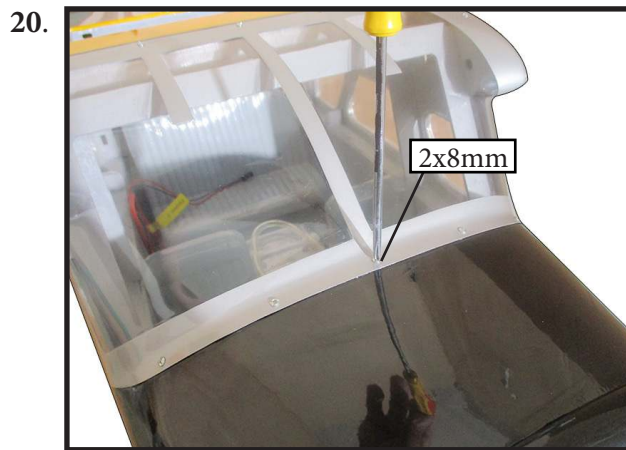

INSTALLING BATTERY - RECEIVER

Plug the servos leads and the switch lead into the receiver. Plug the battery pack lead into the switch also.

Wrap the receiver and battery pack in the protective foam rubber to protect them from vibration.

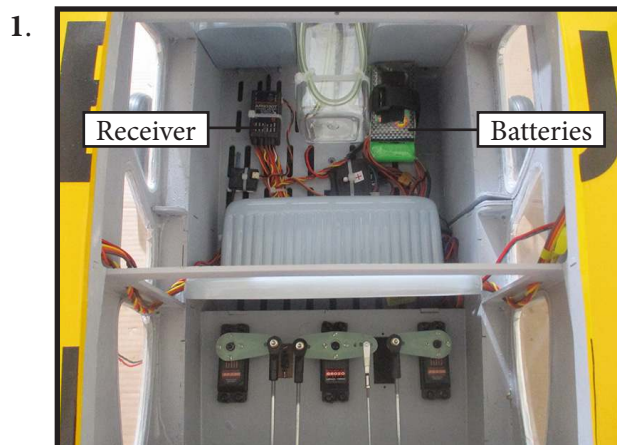
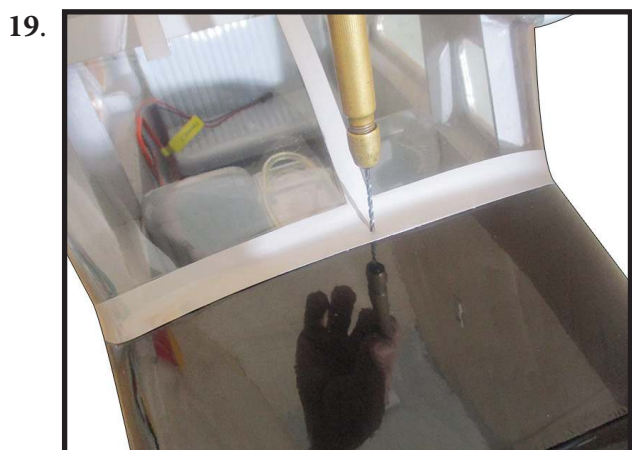

ATTACHMENT WING- FUSELAGE

Parts requirement. See pictures below.

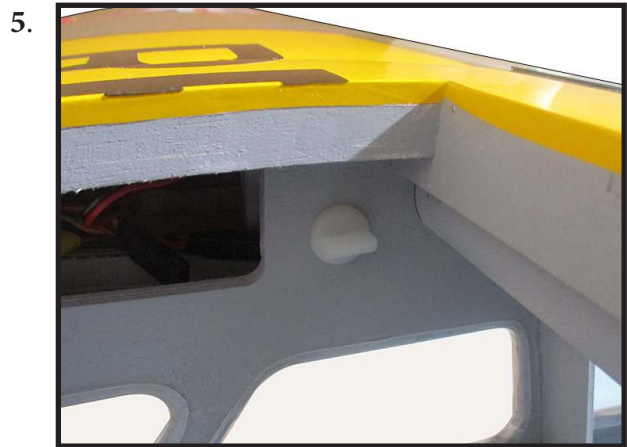
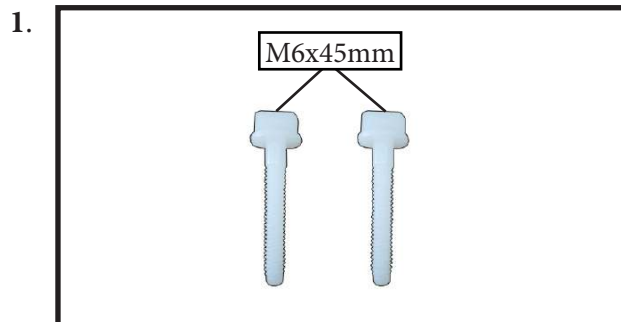

INSTALL THE PLASTIC PARTS

Parts requirement. See pictures below.

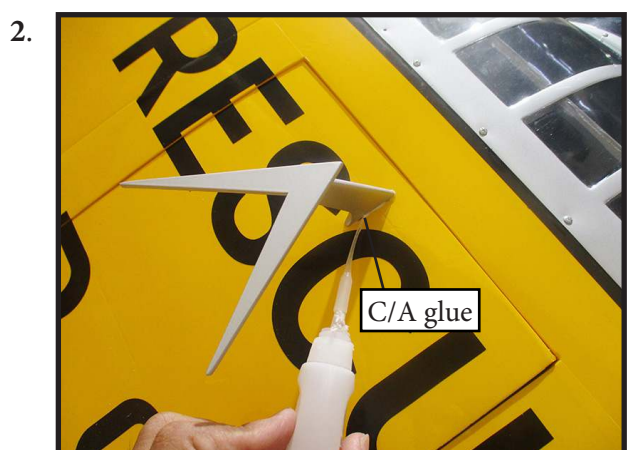



INSTALLING ANTENNAS

Antennas feature banana plugs for easy installation and removal.

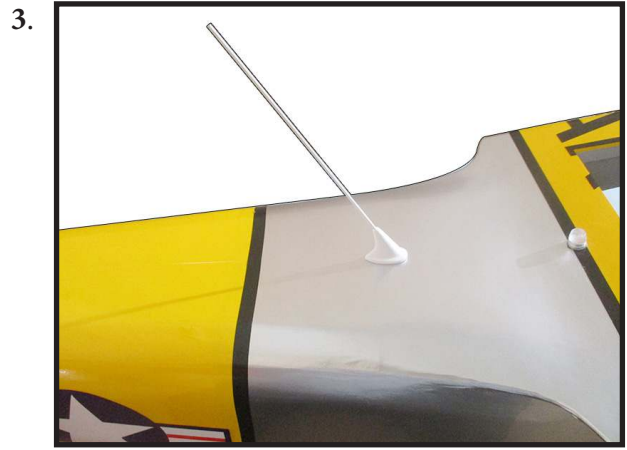
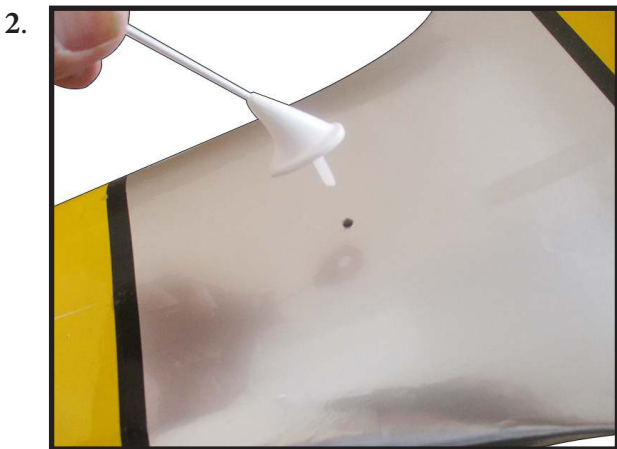
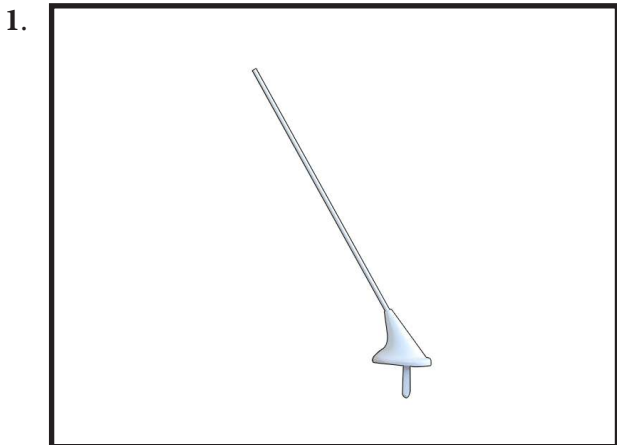

INSTALL PITOT TUBE (PROT WING)

Please study images below.

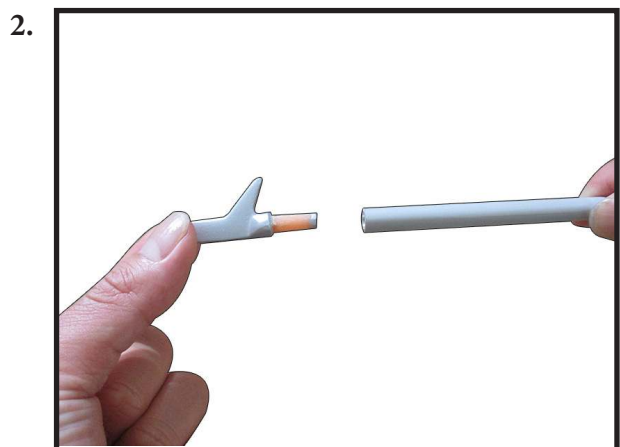
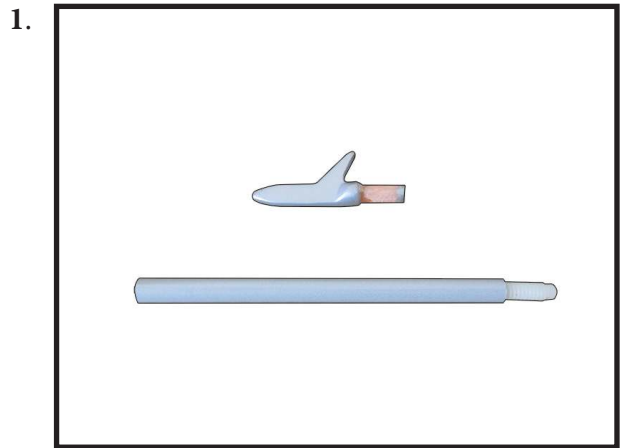

3.

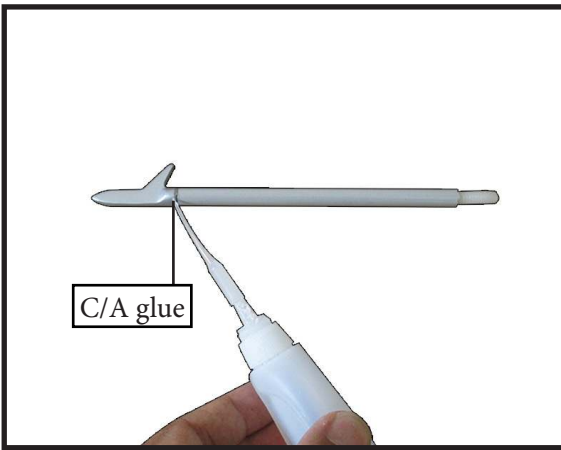

4.



5.



APPLY THE DECALS

If all the decals are precut and ready to stick. Please be certain the model is clean and free from oily fingerprints and dust. Position decal on the model where desired, using the photos on the box and aid in their location.

If all the decals are not precut, please use scissors or a sharp hobby knife to cut the decals from the sheet. Please be certain the model is clean and free from oily fingerprints and dust. Position decal on the model where desired, using the photos on the box and aid in their location.

BALANCING

An important part of preparing the aircraft for flight is properly balancing the model.

1) Attach the wing panels to the fuselage. Make sure to connect the leads from the aileron to the appropriate leads from the receiver. Make sure the leads are not exposed outside the fuselage before tightening the wing bolts. Your model should be flight-ready before balancing.

2) The recommended Center of Gravity (CG) location for your model is (115mm) back from the leading edge at the center of the wing.

3) When balancing your model, make sure it is assembled and ready for flight. Support the plane upright at the marks made on the wing with your fingers or a commercially available balancing stand. This is the correct balance point for your model.

*If possible, first attempt to balance the model by changing the position of the receiver battery and receiver. If you are unable to obtain good balance by doing so, then it will be necessary to add weight to the nose or tail to achieve the proper balance point.

With the wings attached to the fuselage, all parts of the model installed (ready to fly), and empty fuel tanks, hold the model at the marked balance point with the stabilizer level.

Lift the model. If the tail drops when you lift, the model is "tail heavy" and you must add weight* to the nose. If the nose drops, it is "nose heavy" and you must add weight* to the tail to balance.

CONTROL THROWS

Ailerons:	Rudder:
High Rate :	High Rate :
Up : 45mm	Right : 60mm
Down : 45mm	Left : 60mm
Low Rate :	Low Rate :
Up : 25mm	Right : 40mm
Down : 25mm	Left : 40mm
Elevator:	Flap:
High Rate :	Mid : 40mm
Up : 50mm	Full : 55mm
Down : 50mm	
Low Rate :	
Up : 30mm	
Down : 30mm	



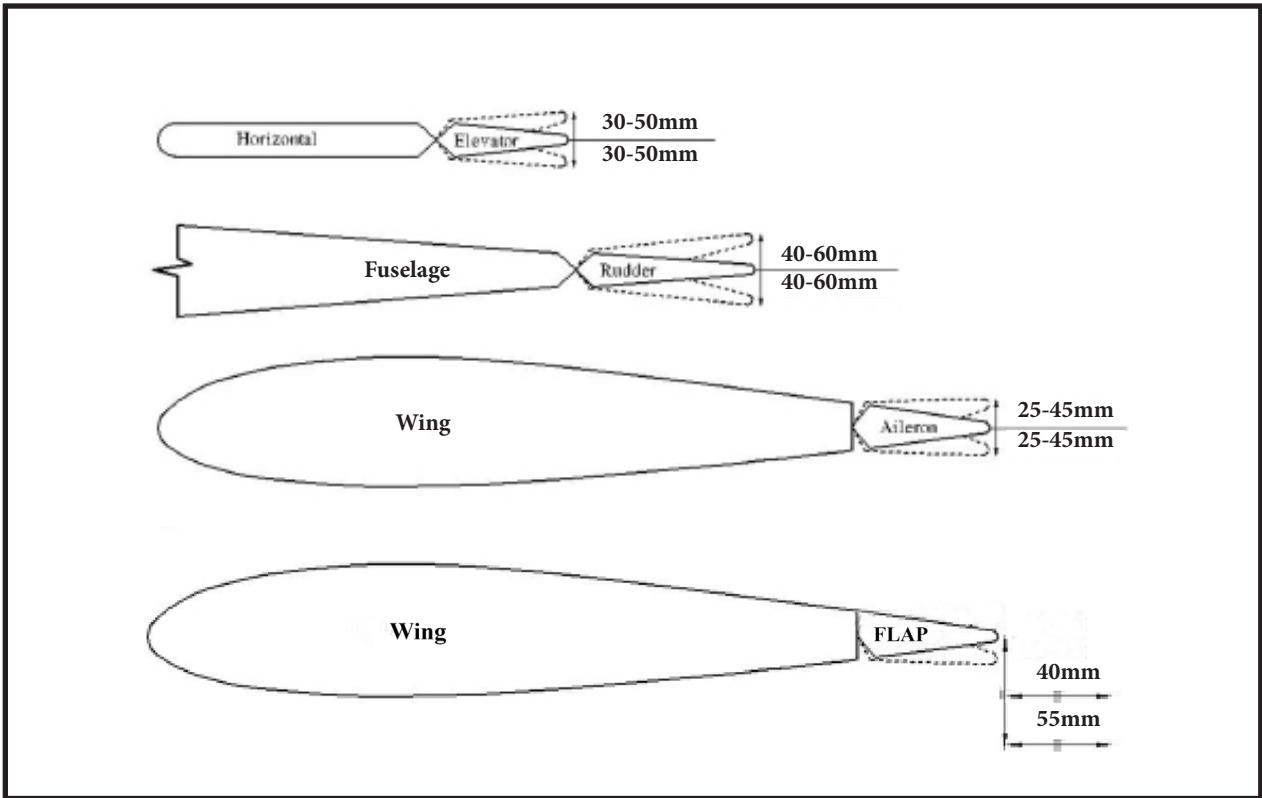

FLIGHT PREPARATION

Check the operation and direction of the elevator, rudder, ailerons and throttle.

A) Plug in your radio system per the manufacturer's instructions and turn everything on.

B) Check the elevator first. Pull back on the elevator stick. The elevator halves should move up. If they do not, flip the servo reversing switch on your transmitter to change the direction.

C) Check the rudder. Looking from behind the airplane, move the rudder stick to the right. The rudder should move to the right. If it does not, flip the servo reversing switch on your transmitter to change the direction.

D) Check the throttle. Moving the throttle stick forward should open the carburetor barrel. If it does not, flip the servo reversing switch on your transmitter to change the direction.

E) From behind the airplane, look at the aileron on the right wing half. Move the aileron stick to the right. The right aileron should move up and the other aileron should move down. If it does not, flip the servo reversing switch on your transmitter to change the direction.

PREFLIGHT CHECK

1) Completely charge your transmitter and receiver batteries before your first day of flying.

2) Check every bolt and every glue joint in the **Cessna 195 ARF 90" wingspan 35–50cc** to ensure that everything is tight and well bonded.

3) Double check the balance of the airplane. Do this with the fuel tank empty.

4) Check the control surfaces. All should move in the correct direction and not bind in any way.

5) If your radio transmitter is equipped with dual rate switches double check that they are on the low rate setting for your first few flights.

6) Check to ensure the control surfaces are moving the proper amount for both low and high rate settings.

7) Check the receiver antenna. It should be fully extended and not coiled up inside the fuselage.

8) Properly balance the propeller. An out of balance propeller will cause excessive vibration which could lead to engine and/or airframe failure.

We wish you many safe and enjoyable flights with your
Cessna 195 ARF 90" wingspan 35–50cc.

*If you have any queries, or are interested in our products,
please feel free to contact us*

Factory : 12/101A - Hamlet 4 - Le Van Khuong Street - Dong Thanh Ward -
Hoc Mon District - Ho Chi Minh City - Viet Nam.

Office : 62/8 Ngo Tat To Street - Ward 19 - Binh Thanh District - Ho Chi Minh
City - Viet Nam

Phone : 848 - 86622289 or 848- 36018777

Website : www.SeagullModels.com

Email : Sales@seagullmodels.com

Facebook : www.facebook.com/SeaGullModels.